



WRX Series

Portable Grain Auger Assembly Manual

This manual applies to the following brands and models:

Westfield, AGI, Hutchinson, Mayrath

8-31, 8-36, 8-41, 8-46, 8-51, 8-56, 8-61, 8-71, 8-76

10-31, 10-36, 10-41, 10-51, 10-61, 10-71

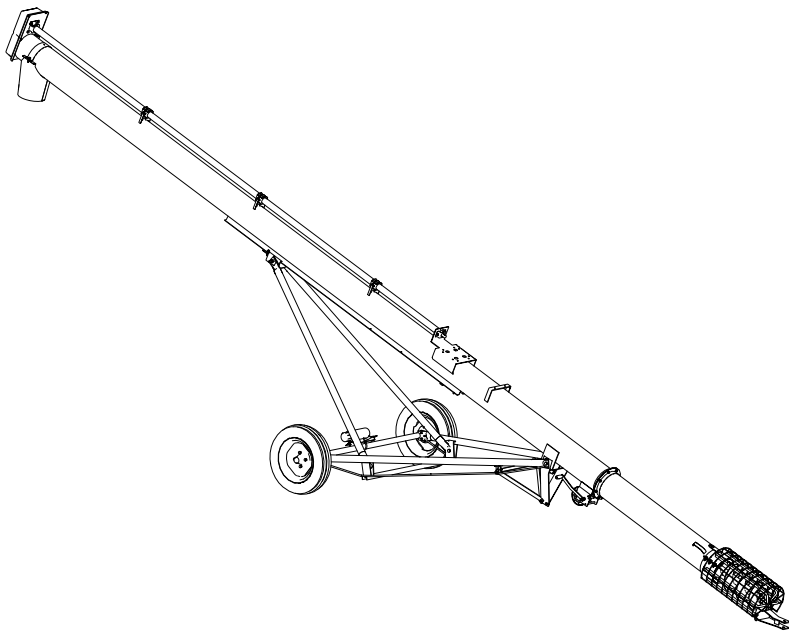

Original Instructions



Read this manual before using product. Failure to follow instructions and safety precautions can result in serious injury, death, or property damage. Keep manual for future reference.

Part Number: 31059 R2

Revised: April 2020

New in this Manual

The following changes have been made in this revision of the manual:

Description	Section
PTO-BD assembly instructions added	Section 4.7 – Install the Driveshaft on page 28 Section 4.8 – Install the Track Stops on page 36 Section 4.16 – Install the Gearbox and Gearbox Brackets on page 48 Section 4.17.1 – Installing Upper and Lower Frame Arms on page 54 Section 4.18 – Attach Frame to Tube on page 56
Modified PTO-SD instructions to be laid out better in the manual; driveshaft instructions laid out separately from drive; gearbox installation now further forward in manual	Section 4.7 – Install the Driveshaft on page 28 Section 4.16 – Install the Gearbox and Gearbox Brackets on page 48
Only one sprocket must be replaced for PTO-SD	Section 4.10 – Install the Sprocket Head Gearing on page 39
New Poly Guard for MD	Section 4.21 – Install the Motor Drive on page 69

CONTENTS

- 1. Introduction 5**
- 2. Safety..... 6**
 - 2.1 Safety Alert Symbol and Signal Words..... 6
 - 2.2 General Safety 6
 - 2.3 Rotating Flighting Safety 7
 - 2.4 Rotating Parts Safety..... 7
 - 2.5 Hand Winch Safety 7
 - 2.6 Drives and Lockout Safety..... 7
 - 2.6.1 Gas Engine Safety..... 8
 - 2.6.2 Electric Motor Safety..... 8
 - 2.6.3 PTO Driveline Safety..... 9
 - 2.6.4 Hydraulic Power Safety 10
 - 2.7 Tire Safety..... 11
 - 2.8 Battery Safety 11
 - 2.9 Personal Protective Equipment..... 12
 - 2.10 Safety Equipment 12
 - 2.11 Safety Decals 13
 - 2.11.1 Decal Installation/Replacement..... 13
 - 2.11.2 Safety Decal Locations and Details 13
- 3. Features..... 23**
- 4. Assembly 24**
 - 4.1 Assembly Safety 24
 - 4.2 Check Shipment..... 24
 - 4.3 Before You Begin 24
 - 4.4 Brand and Model Decal Placement 25
 - 4.5 Assembly Overview 26
 - 4.6 Assemble Tube & Flighting..... 27
 - 4.7 Install the Driveshaft 28
 - 4.7.1 Driveshaft Layout Drawings 28
 - 4.7.2 Assemble the Driveshaft 33
 - 4.8 Install the Track Stops 36
 - 4.9 Install the Spout 38
 - 4.10 Install the Sprocket Head Gearing 39
 - 4.11 Add Grease to Head Cover..... 40
 - 4.12 Install the Intake Cage..... 41
 - 4.13 Install the Hitch 42
 - 4.14 Install the Lift Cable..... 42
 - 4.15 Install Truss Towers and Truss Cable 44
 - 4.15.1 Install Truss Towers..... 44
 - 4.15.2 Install Truss Cable..... 46
 - 4.16 Install the Gearbox and Gearbox Brackets 48
 - 4.16.1 EMD/MD..... 48
 - 4.16.2 PTO-SD..... 50
 - 4.16.3 PTO-BD 51
 - 4.17 Assemble the Frame..... 54
 - 4.17.1 Installing Upper and Lower Frame Arms 54
 - 4.17.2 Install the Frame Extensions 56

4.18 Attach Frame to Tube	56
4.18.1 Attach Upper and Lower Frame Arms	57
4.18.2 Attach Stabilizer Pieces	59
4.19 Install the Manual Winch and Connect the Lift Cable	60
4.20 Install the Electric Motor Drive	61
4.20.1 Install the EMD Mount Assembly	61
4.20.2 Install the Backplate Mount	62
4.20.3 Install the Electric Motor	63
4.20.4 Install the EMD Belt Guard Assembly	64
4.20.5 Install the Pulleys	65
4.20.6 Install the Belt	66
4.20.7 Tension the Belt	67
4.21 Install the Motor Drive	69
4.21.1 Install the Motor Mount	70
4.21.2 Install the Battery and Fuel Tank (Gas Motor Only)	74
4.21.3 Install the Motor	75
4.21.4 Install the Engine Pulley	76
4.21.5 Install the Gearbox Pulley	77
4.21.6 Install the Belt	77
4.22 Install the PTO-SD	78
4.22.1 Install the PTO Shield	78
4.22.2 Install the PTO	78
4.22.3 Install the Saddle Bracket	79
4.23 Install the PTO-BD	80
4.23.1 Install Frame Support Tubes	80
4.23.2 Install Jackshaft Assembly	81
4.23.3 Install the Pulleys	81
4.23.4 Install the Belts	82
4.23.5 Install Pulley Guards	83
4.23.6 Install the PTO Shield	84
4.23.7 Install the PTO	85
4.23.8 Install PTO Transport Holder	85
4.24 Install the Hydraulic Drive	86
4.24.1 Install the Half Clamps	86
4.24.2 Install the Hydraulic Motor Mount Assembly	88
4.24.3 Install the Hydraulic Hoses	89
4.25 Install Manual Holder	89
5. Specifications	91
6. Appendix	95
6.1 Bolt Torque	95

1. Introduction

This manual describes how to assemble a Westfield Portable Grain Auger.

Before assembling, please read this manual. Familiarize yourself with the process and the necessary precautions for efficient and safe assembly.

Everyone present at the assembly site is required to be familiar with all safety precautions.

Keep this manual available for frequent reference and review it with new personnel. Call your local distributor or dealer if you need assistance or additional information.

2. Safety

2.1. Safety Alert Symbol and Signal Words



This safety alert symbol indicates important safety messages in this manual. When you see this symbol, be alert to the possibility of injury or death, carefully read the message that follows, and inform others.

Signal Words: Note the use of the signal words **DANGER**, **WARNING**, **CAUTION**, and **NOTICE** with the safety messages. The appropriate signal word for each message has been selected using the definitions below as a guideline.



DANGER Indicates an imminently hazardous situation that, if not avoided, will result in serious injury or death.



WARNING Indicates a hazardous situation that, if not avoided, could result in serious injury or death.



CAUTION Indicates a hazardous situation that, if not avoided, may result in minor or moderate injury.



NOTICE Indicates a potentially hazardous situation that, if not avoided, may result in property damage.

2.2. General Safety

It is the auger assembler and installation personnel's responsibility to read and understand **ALL** safety instructions, safety decals, and manuals and follow them when assembling, operating, or maintaining the equipment.

- Only experienced personnel who are familiar with this type of assembly and installation should perform this work. Untrained assemblers/installers expose themselves and bystanders to possible serious injury or death.
- Do not modify the auger in any way without written permission from the manufacturer. Unauthorized modification may impair the function and/or safety. Any unauthorized modification will void the warranty.
- Follow a health and safety program for your worksite. Contact your local occupational health and safety organization for information.
- Contact your local representative or Westfield if you need assistance or additional information.



2.3. Rotating Flighting Safety

DANGER

- KEEP AWAY from rotating flighting.
- DO NOT remove or modify flighting guards, doors, or covers. Keep in good working order. Have replaced if damaged.
- DO NOT operate the auger without all guards, doors, and covers in place.
- NEVER touch the flighting. Use a stick or other tool to remove an obstruction or clean out.
- Shut off and lock out power to adjust, service, or clean.



2.4. Rotating Parts Safety

WARNING

- Keep body, hair, and clothing away from rotating pulleys, belts, chains, and sprockets.
- Do not operate with any guard removed or modified. Keep guards in good working order.
- Shut off and remove key or lock out power source before inspecting or servicing machine.



2.5. Hand Winch Safety

WARNING

When Equipped:

- Inspect lift cable before using. Replace if frayed or damaged. Make sure lift cable is seated properly in cable sheaves and cable clamps are secure.
- Tighten brake lock by turning winch handle clockwise at least two clicks after lowering the auger.
- Lower the auger fully before towing, then rotate winch handle until cable has light tension.
- Do not lubricate winch brake discs.

2.6. Drives and Lockout Safety

Inspect the power source(s) before using and know how to shut down in an emergency. Whenever you service or adjust your equipment, make sure you shut down the power source and unplug or remove the key (as applicable) to prevent inadvertent start-up and hazardous energy release. Know the procedure(s) that applies to your equipment from the following power source(s). Ensure that all personnel are clear before turning on power to equipment.



2.6.1 Gas Engine Safety

WARNING Power Source

- Keep guards in place and secure.
- Properly ventilate surrounding area.
- Never fill the fuel tank with the engine running, while smoking, or near an open flame. Always shut down and allow engine to cool before filling with fuel.
- Never overfill the tank or spill fuel. If fuel is spilled, clean it up immediately.
- Be sure to use the correct type and grade of fuel. Ground the fuel funnel or nozzle against the filler neck to prevent sparks that could ignite fuel vapors.
- Be sure to replace the fuel fill cap when you are done.



Lockout

- For engines with an electric start, remove the ignition key, the spark plug wire, or the spark plug.
- For engines with a rope or crank start, remove the spark plug wire or the spark plug.

2.6.2 Electric Motor Safety

WARNING Power Source

- Electric motors and controls shall be installed and serviced by a qualified electrician and must meet all local codes and standards.
- A magnetic starter should be used to protect your motor.
- You must have a manual reset button.
- Reset and motor starting controls must be located so that the operator has full view of the entire operation.
- Locate main power disconnect switch within reach from ground level to permit ready access in case of an emergency.
- Motor must be properly grounded.
- Ensure electrical wiring and cords remain in good condition; replace if necessary.

Lockout

- The main power disconnect switch should be in the locked position during shutdown or whenever maintenance is performed.
- If reset is required, disconnect all power **before** resetting motor.

SERVICE DISCONNECT

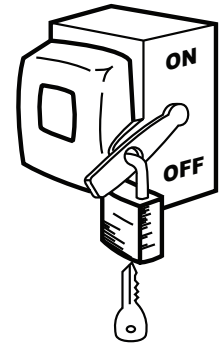

2.6.3 PTO Driveline Safety

WARNING Drive

- Keep body, hair, and clothing away from rotating PTO driveline.
- Make certain the driveline shields telescope and rotate freely on driveline before attaching.
- Make certain the driveline is securely attached at both ends.
- Do not operate auger unless all driveline, tractor, and equipment shields are in place and in good working order.
- Do not exceed the specified operating speed.
- Keep universal joint angles small and equal. Do not exceed maximum recommended length for PTO driveline.
- Engage tractor park brake and/or chock wheels.

Lockout

- Position all controls in neutral, shut off tractor's engine, and remove key from tractor.
- If removing key is impossible, remove PTO driveline from tractor.



2.6.4 Hydraulic Power Safety

WARNING Power Source

- Refer to the rules and regulations applicable to the power source operating your hydraulic drive.
- Do not connect or disconnect hydraulic lines while system is under pressure.
- Keep all hydraulic lines away from moving parts and pinch points.
- Escaping hydraulic fluid under pressure will cause serious injury if it penetrates the skin surface (serious infection or toxic reaction can develop). See a doctor immediately if injured.
- Use metal or wood as a backstop when searching for hydraulic leaks and wear proper hand and eye protection.
- Check all hydraulic components are tight and in good condition. Replace any worn, cut, abraded, flattened, or crimped hoses.
- Clean the connections before connecting to equipment.
- Do not attempt any makeshift repairs to the hydraulic fittings or hoses with tape, clamps, or adhesive. The hydraulic system operates under extremely high pressure; such repairs will fail suddenly and create a hazardous and unsafe condition.

Lockout

- Always place all hydraulic controls in neutral and relieve system pressure before disconnecting or working on hydraulic system.



2.7. Tire Safety

WARNING Failure to follow proper procedures when mounting a tire on a wheel or rim can produce an explosion that may result in serious injury or death.



- DO NOT attempt to mount a tire unless you have the proper equipment and experience to do the job.
- Have a qualified tire dealer or repair service perform required tire maintenance.
- When replacing worn tires, make sure they meet the original tire specifications. Never undersize the replacement tire.
- DO NOT weld to the tire rim with the tire mounted on the rim. This action may cause an explosion which could result in serious injury or death.
- Inflate tires to the manufacturer's recommended pressure.
- Tires should not be operated at speeds higher than their rated speed.
- Keep wheel lug nuts tightened to manufacturer's recommendations.
- Never reinflate a tire that has been run flat or seriously under-inflated without removing the tire from the wheel. Have the tire and wheel closely inspected for damage before remounting.

2.8. Battery Safety

- WARNING**
- Wear safety glasses and protective gloves when working near batteries.
 - Make certain the battery or terminal covers are in place and in good working order.
 - Keep all sparks and flames away from batteries; gas given off by electrolyte is explosive.
 - Avoid contact with battery electrolyte. Wash off any spilled electrolyte immediately.
 - Do not tip batteries more than 45° to avoid electrolyte loss.
 - To avoid injury from sparks or short circuits, disconnect battery ground cable before servicing any part of an electrical system.



2.9. Personal Protective Equipment

The following Personal Protective Equipment (PPE) should be worn when assembling the equipment.

Safety Glasses

- Wear safety glasses at all times to protect eyes from debris.

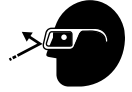

Coveralls

- Wear coveralls to protect skin.



Hard Hat

- Wear a hard hat to help protect your head.



Steel-Toe Boots

- Wear steel-toe boots to protect feet from falling debris.



Work Gloves

- Wear work gloves to protect your hands from sharp and rough edges.



2.10. Safety Equipment

The following safety equipment should be kept on site:

Fire Extinguisher

- Provide a fire extinguisher for use in case of an accident. Store in a highly visible and accessible place.



First-Aid Kit

- Have a properly-stocked first-aid kit available for use should the need arise, and know how to use it.



2.11. Safety Decals

- Keep safety decals clean and legible at all times.
- Replace safety decals that are missing or have become illegible. See decal location figures that follow.
- Replaced parts must display the same decal(s) as the original part.
- Replacement safety decals are available **free of charge** from your distributor, dealer, or factory as applicable.

2.11.1 Decal Installation/Replacement

1. Decal area must be clean and dry, with a temperature above 50°F (10°C).
2. Decide on the exact position before you remove the backing paper.
3. Align the decal over the specified area and carefully press the small portion with the exposed sticky backing in place.
4. Slowly peel back the remaining paper and carefully smooth the remaining portion of the decal in place.
5. Small air pockets can be pierced with a pin and smoothed out using the sign backing paper.

2.11.2 Safety Decal Locations and Details

Replicas of the safety decals that are attached to the auger and their messages are shown in the figure(s) that follow. Safe operation and use of the auger requires that you familiarize yourself with the various safety decals and the areas or particular functions that the decals apply to, as well as the safety precautions that must be taken to avoid serious injury, death, or damage.

Figure 1. Safety Decal Locations for Basic Auger

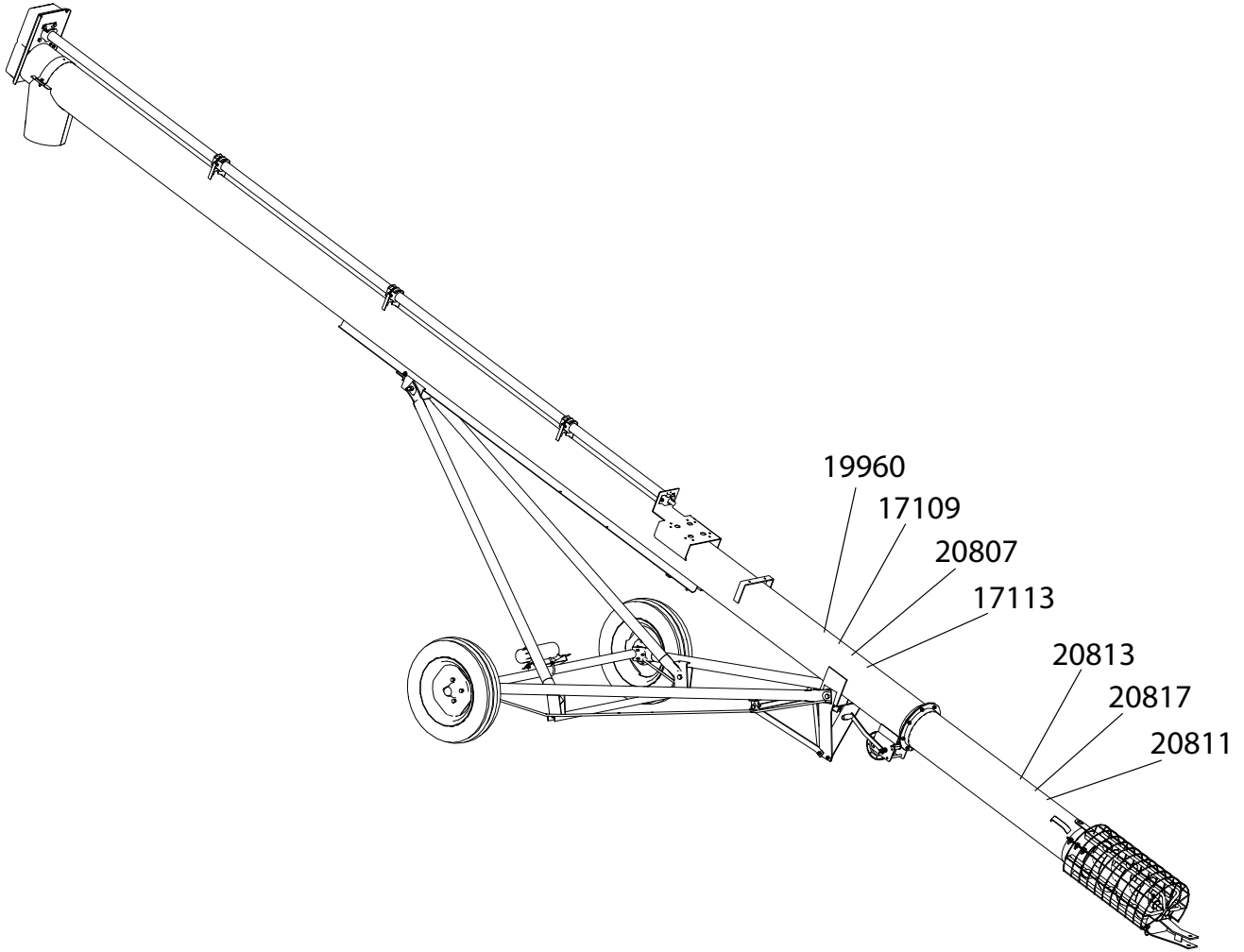

Figure 2. Safety Decal Locations for EMD Option

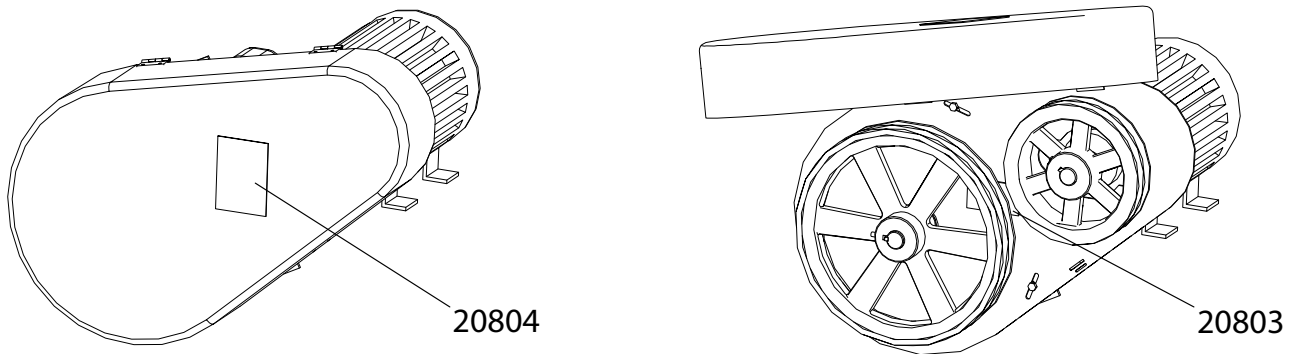

Figure 3. Safety Decal Locations for MD Option

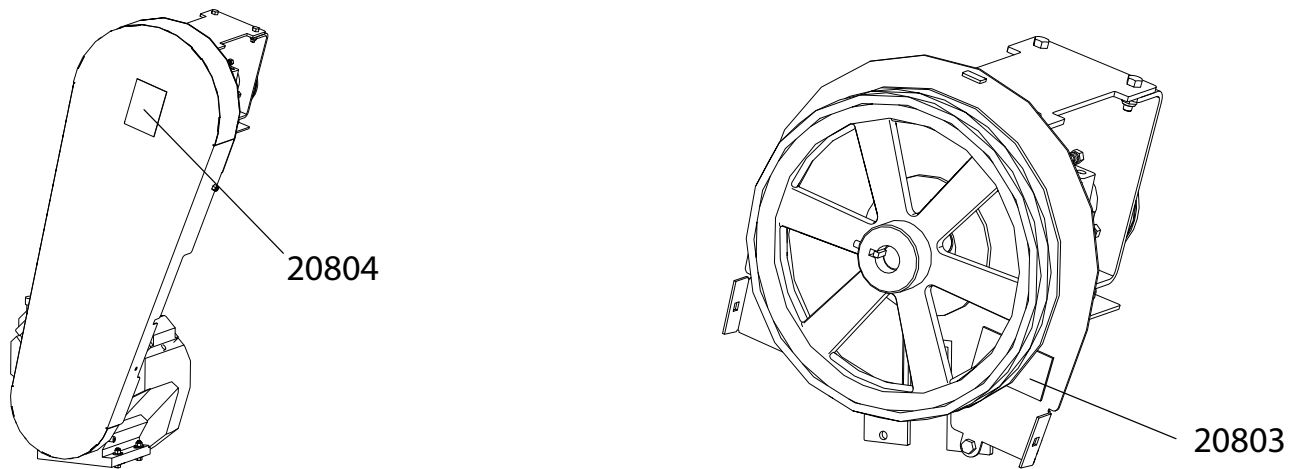

Figure 4. Safety Decal Locations for PTO-SD Option

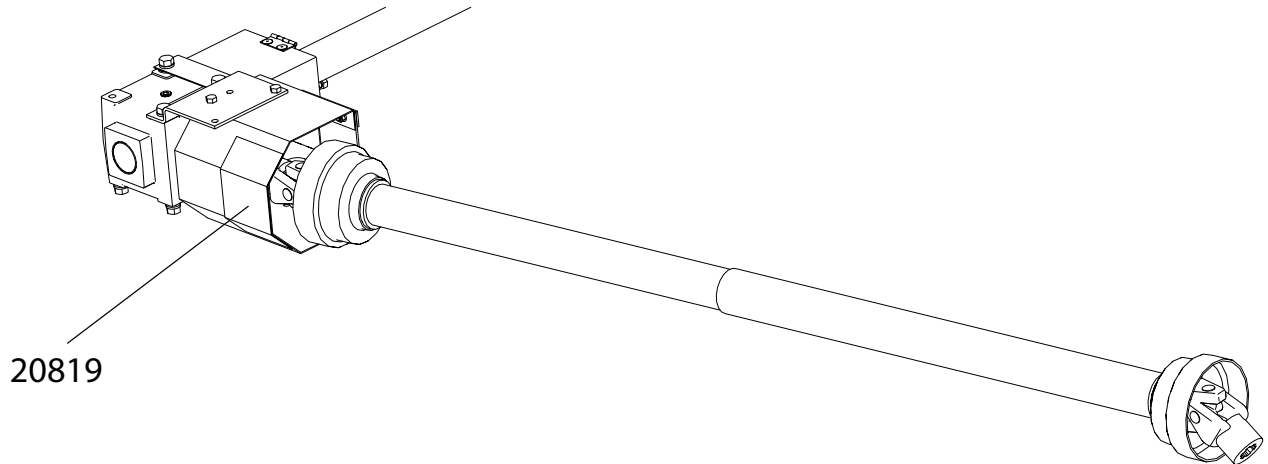

Figure 5. Safety Decal Locations for PTO-BD Option

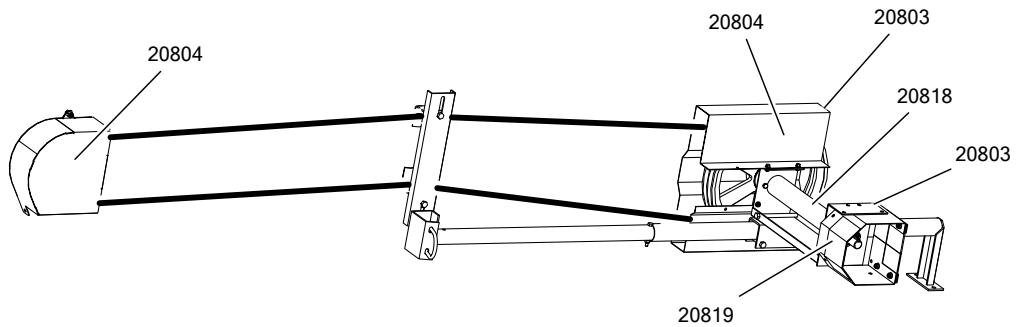

Figure 6. Safety Decal Locations for Hydraulic Drive Option

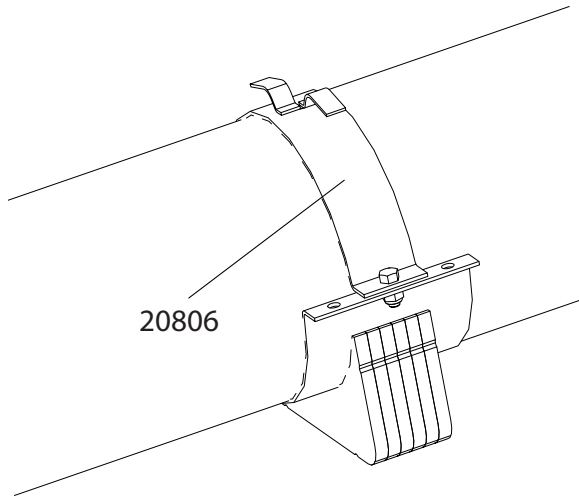

Table 1. Safety Decals

Part Number	Description
20813	<div style="border: 1px solid black; padding: 10px;"> <div style="background-color: red; color: white; text-align: center; padding: 5px;">⚠ DANGER</div> <div style="display: flex; justify-content: space-around; align-items: center; margin-top: 10px;">   </div> <div style="margin-top: 10px;"> <p>ROTATING FLIGHTING HAZARD</p> <p>To prevent death or serious injury:</p> <ul style="list-style-type: none"> • KEEP AWAY from rotating auger flighting. • DO NOT remove or modify auger flighting guards, doors, or covers. Keep in good working order. Have replaced if damaged. • DO NOT operate the auger without all guards, doors, and covers in place. • NEVER touch the auger flighting. Use a stick or other tool to remove an obstruction or clean out. • Shut off and lock out power to adjust, service, or clean. </div> </div>

Table 1 Safety Decals (continued)

Part Number	Description
20819	<div style="border: 1px solid black; padding: 5px;"> <div style="background-color: red; color: white; text-align: center; padding: 2px;"> DANGER</div> <div style="display: flex; justify-content: space-around; align-items: center; margin-top: 5px;">   </div> <div style="text-align: center; margin-top: 10px;">ROTATING PTO DRIVELINE</div> <p>To prevent serious injury or death:</p> <ul style="list-style-type: none"> • Keep body, hair, and clothing away from rotating PTO driveline. • Do not operate equipment unless all driveline, tractor, and equipment shields are in place and in good working order. • Make certain the driveline shields turn freely on driveline. • Make certain the driveline is securely attached at both ends. • Do not exceed specified operating speed (see operator's manual). • Keep u-joint angles small and equal. Do not exceed maximum recommended length for PTO driveline. </div>
20817	<div style="border: 1px solid black; padding: 5px;"> <div style="background-color: red; color: white; text-align: center; padding: 2px;"> DANGER</div> <div style="display: flex; justify-content: space-around; align-items: center; margin-top: 5px;">   </div> <div style="text-align: center; margin-top: 10px;">ELECTROCUTION HAZARD</div> <p>To prevent death or serious injury:</p> <ul style="list-style-type: none"> • When operating or moving, keep equipment away from overhead power lines and devices. • Fully lower equipment before moving. <p>This equipment is not insulated. Electrocution can occur without direct contact.</p> </div>

Table 1 Safety Decals (continued)



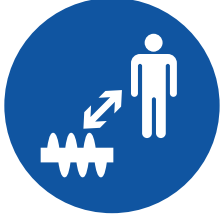



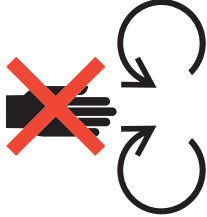
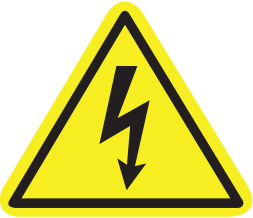
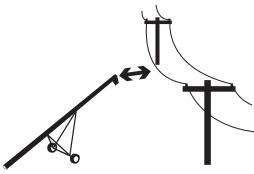





Part Number	Description				
20803 (placed on machine behind guard)	<div style="border: 1px solid black; padding: 5px;"> <div style="background-color: #f4a460; padding: 2px; text-align: center;">  WARNING </div> <table border="1" style="width: 100%; border-collapse: collapse;"> <tr> <td style="width: 30%; text-align: center; vertical-align: middle;">  </td> <td style="padding: 5px;"> <p>MISSING GUARD HAZARD</p> <p>To prevent serious injury or death, shut off power and reattach guard before operating machine.</p> </td> </tr> <tr> <td style="text-align: center; vertical-align: middle;">  </td> <td></td> </tr> </table> </div>		<p>MISSING GUARD HAZARD</p> <p>To prevent serious injury or death, shut off power and reattach guard before operating machine.</p>		
	<p>MISSING GUARD HAZARD</p> <p>To prevent serious injury or death, shut off power and reattach guard before operating machine.</p>				
					
20804	<div style="border: 1px solid black; padding: 5px;"> <div style="background-color: #f4a460; padding: 2px; text-align: center;">  WARNING </div> <table border="1" style="width: 100%; border-collapse: collapse;"> <tr> <td style="width: 50%; text-align: center; vertical-align: middle;">  </td> <td style="width: 50%; text-align: center; vertical-align: middle;">  </td> </tr> <tr> <td colspan="2" style="padding: 5px;"> <p style="text-align: center;">ENTANGLEMENT HAZARD</p> <p>To prevent serious injury or death:</p> <ul style="list-style-type: none"> • Keep body, hair, and clothing away from rotating pulleys, belts, chains, and sprockets. • Do not operate with any guard removed or modified. Keep guards in good working order. • Shut off and remove key or lock out power source before inspecting or servicing machine. </td> </tr> </table> </div>			<p style="text-align: center;">ENTANGLEMENT HAZARD</p> <p>To prevent serious injury or death:</p> <ul style="list-style-type: none"> • Keep body, hair, and clothing away from rotating pulleys, belts, chains, and sprockets. • Do not operate with any guard removed or modified. Keep guards in good working order. • Shut off and remove key or lock out power source before inspecting or servicing machine. 	
					
<p style="text-align: center;">ENTANGLEMENT HAZARD</p> <p>To prevent serious injury or death:</p> <ul style="list-style-type: none"> • Keep body, hair, and clothing away from rotating pulleys, belts, chains, and sprockets. • Do not operate with any guard removed or modified. Keep guards in good working order. • Shut off and remove key or lock out power source before inspecting or servicing machine. 					

Table 1 Safety Decals (continued)

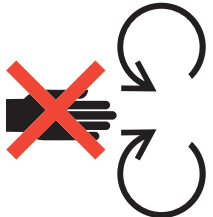

Part Number	Description
20807	<div style="border: 1px solid black; padding: 10px;"> <div style="background-color: #f4a460; text-align: center; padding: 5px;">  WARNING </div> <div style="display: flex; justify-content: space-around; margin-top: 10px;"> <div style="text-align: center;">  </div> <div style="text-align: center;">  </div> </div> <div style="margin-top: 10px;"> <p>To prevent serious injury or death:</p> <ul style="list-style-type: none"> • Read and understand the manual before assembling, operating, or maintaining the equipment. • Only trained personnel may assemble, operate, or maintain the equipment. • Children and untrained personnel must be kept outside of the work area. • Do not modify the equipment. Keep in good working order. • If the manual, guards, or decals are missing or damaged, contact factory or representative for free replacements. • Lock out power before performing maintenance. • To prevent equipment collapse or upending, support equipment tube while disassembling certain components. • Electric motors must be grounded. Disconnect power before resetting overloads. </div> </div>

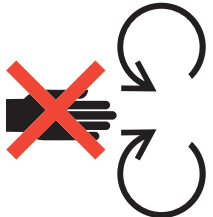
Table 1 Safety Decals (continued)

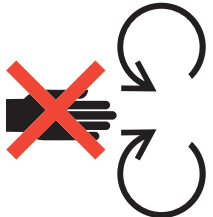
Part Number	Description
20811	<div style="border: 1px solid black; padding: 5px;"> <div style="background-color: #f4a460; text-align: center; padding: 2px;"> WARNING</div> <div style="display: flex; justify-content: space-around; align-items: center; padding: 5px;"> </div> <div style="text-align: center; padding: 5px;">UPENDING HAZARD</div> <p>To prevent death or serious injury:</p> <ul style="list-style-type: none"> • Anchor intake end and/or support discharge end to prevent upending. • Intake end must always have downward weight. Do not release until attached to tow bar or resting on ground. • Do not raise intake end above tow bar height. • Empty tube and fully lower before moving. </div>
17113	<div style="border: 1px solid black; padding: 5px;"> <div style="background-color: #f4a460; text-align: center; padding: 2px;"> WARNING</div> <div style="text-align: center; padding: 5px;">TRANSPORT HAZARD</div> <p>To prevent serious injury or death:</p> <ul style="list-style-type: none"> • Securely attach equipment to vehicle with correct pin and safety chains. • Use a tow vehicle to move equipment. </div>
20806	<div style="border: 1px solid black; padding: 5px;"> <div style="display: flex; justify-content: space-between; align-items: center; padding: 5px;"> <div style="width: 30%; text-align: center;"> </div> <div style="width: 65%;"> <div style="background-color: #f4a460; text-align: center; padding: 2px;"> WARNING</div> <div style="text-align: center; padding: 5px;">HIGH PRESSURE FLUID HAZARD</div> <p>Hydraulic fluid can cause serious injury if it penetrates the skin. If it does, see a doctor immediately.</p> <ul style="list-style-type: none"> • Relieve system pressure before repairing, adjusting or disconnecting. • Wear proper hand and eye protection when searching for leaks. Use wood or cardboard instead of hands. </div> </div> </div>

Table 1 Safety Decals (continued)

Part Number	Description
17109	<div style="border: 1px solid black; padding: 10px;"> <div style="background-color: yellow; text-align: center; padding: 5px;">⚠ CAUTION</div> <p>For proper raising and lowering of equipment:</p> <ul style="list-style-type: none"> • After lowering equipment, always tighten brake lock by turning winch handle clockwise at least two clicks. • Rotate winch handle until cable has light tension, when in towing position. • Do not lubricate winch brake discs. • Inspect lift cable periodically; replace if damaged. • Inspect cable clamps periodically; tighten if necessary. </div>
19960	<div style="border: 1px solid black; padding: 10px;"> <div style="background-color: blue; color: white; text-align: center; padding: 5px;">NOTICE</div> <p>To prevent damage, wheels must be free to move when raising or lowering equipment.</p> <p>When equipment is positioned, chock all wheels.</p> </div>

3. Features

This section covers the main features of the auger.

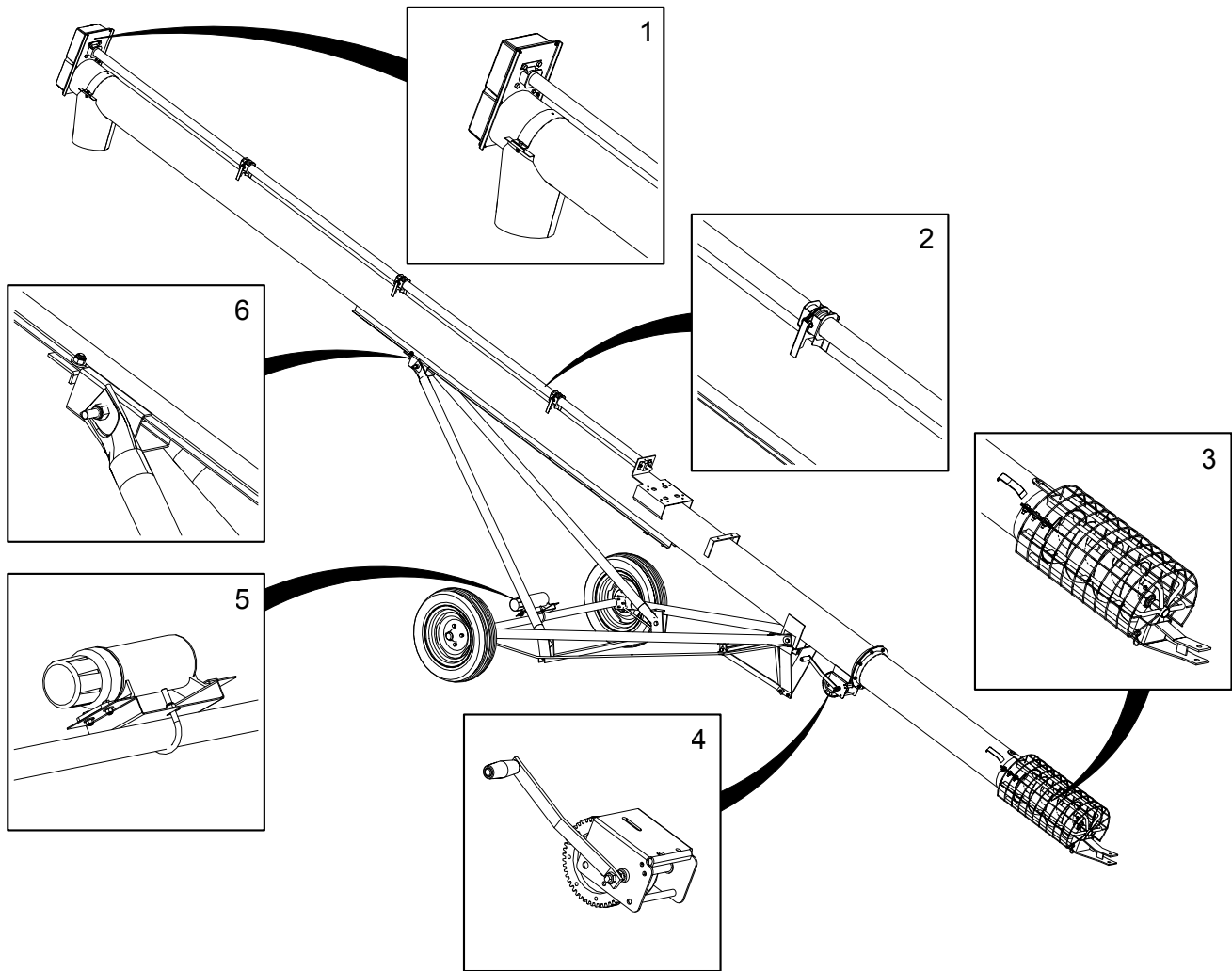

Item	Description	Item	Description
1	Discharge & Upper Chain Drive	4	Manual Winch
2	Shaft Guarding	5	Manual Holder
3	Intake & Intake Guarding	6	Track

4. Assembly



Before continuing, ensure you have completely read and understood this manual's Safety section, in addition to the safety information in the section(s) below.

4.1. Assembly Safety

WARNING

- Do not take chances with safety. The components can be large, heavy, and hard to handle. Always use the proper tools, rated lifting equipment, and lifting points for the job.
- Carry out assembly in a large open area with a level surface.
- Always have two or more people assembling the auger.
- Make sure you have sufficient lighting for the work area.
- Tighten all fasteners according to their specifications. Do not replace or substitute bolts, nuts, or other hardware that is of lesser quality than the hardware supplied by the manufacturer.

4.2. Check Shipment

Unload the auger parts at the assembly site and compare the packing slip to the shipment. Ensure that all items have arrived and that none are damaged.

Report missing or damaged parts immediately to ensure that proper credit is received from Westfield or your representative, and to ensure that any missing parts can be shipped quickly to avoid holding up the assembly process.

Important

Do not assemble or install damaged components.

4.3. Before You Begin

Before you assemble the auger:

- Familiarize yourself with all the sub-assemblies, components, and hardware that make up the equipment.
- Have all parts and components on hand, and arrange them for easy access.
- Separate the hardware (bolts, nuts, etc.) and lay them out into groups for easier identification during assembly.
- If assembling inside, confirm the ceiling and door width/height provide enough clearance when installing the undercarriage and to remove the auger from the building.
- Ensure there is adequate space to remove the assembled auger from the assembly area.

4.4. Brand and Model Decal Placement

Important

Do not cover any existing safety or instruction decals with the model decals.

1. Apply decals to both sides of auger tube.
2. Center decals vertically and apply to auger tube.

Brand Decal Location

UPPER TUBE

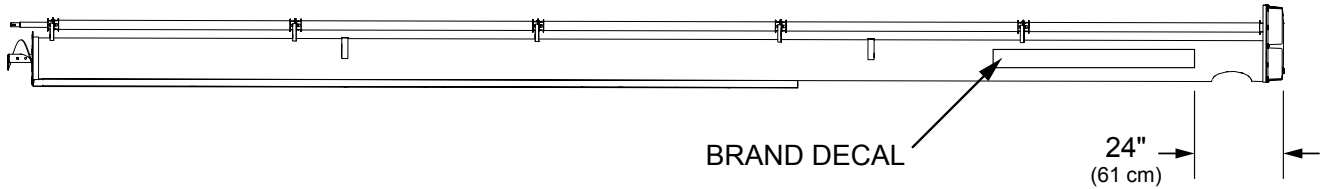

Model Decal Locations

	31'	36'	41'
X	8' (2.44 m)	3'6" (1.07 m)	2' (0.61 m)

UPPER TUBE (31'/36'/41' ONLY)

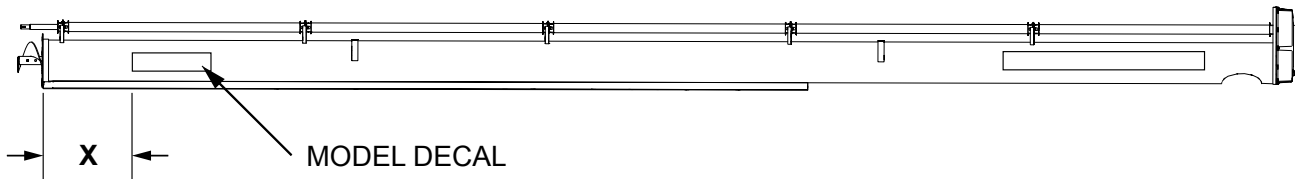

MIDDLE TUBE (56'/61'/71'/76' ONLY)

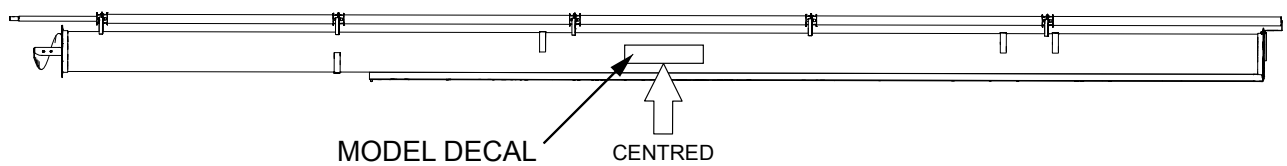

LOWER TUBE (46'/51' ONLY)

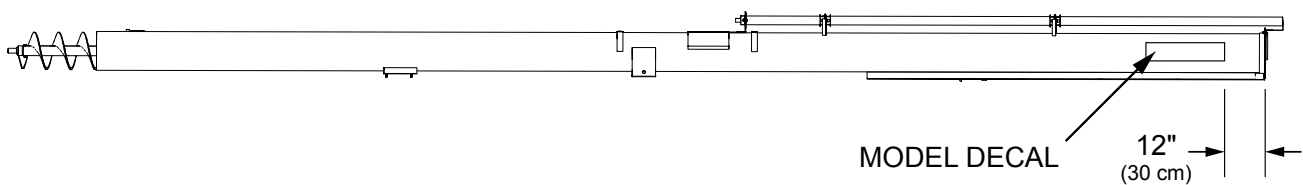

4.5. Assembly Overview

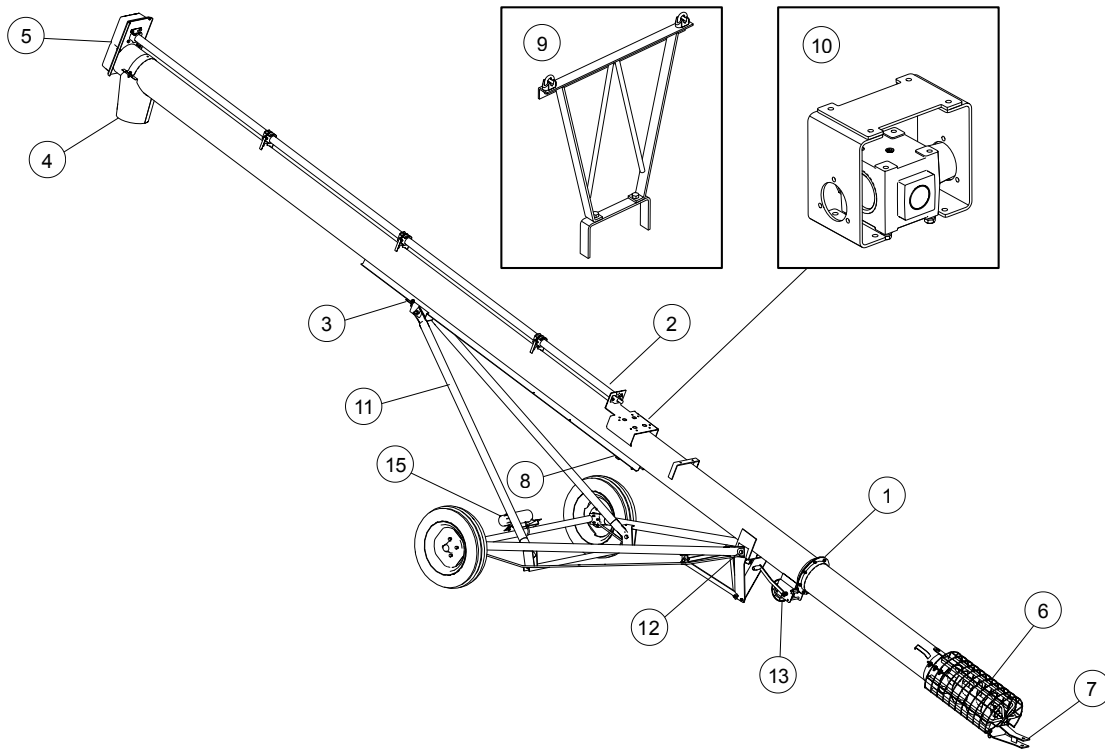

Sequence	Description
1	Assemble Tube & Flighting
2	Assemble Driveshaft
3	Install Track Stops
4	Install Spout
5	Add Grease to Head Cover
6	Install Intake Cage
7	Install Hitch
8	Install Lift Cable
9	Install Truss Towers and Truss Cable (46'-76' Models only)
10	Install Gearbox and Gearbox Brackets (not required for Hydraulic Drive)
11	Assemble the Frame
12	Attach Frame to Tube
13	Install Manual Winch and Connect Lift Cable
14	Install the Drive (Electric Motor Drive/Motor Drive/PTO-SD/PTO-BD/Hydraulic)
15	Install Manual Holder

4.6. Assemble Tube & Flighting

8" Models

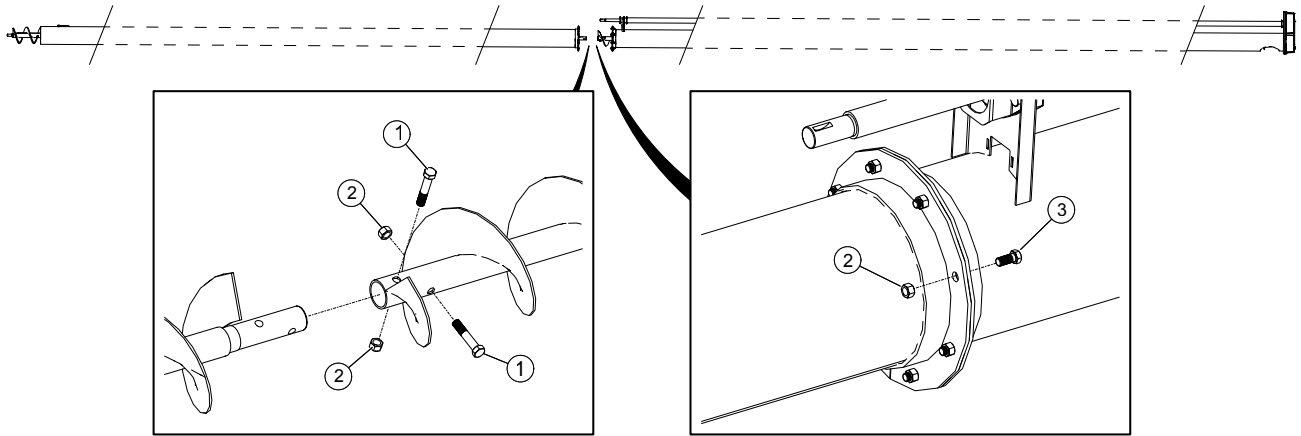

1	Bolt, 7/16" x 2-1/4"	3	Bolt, 7/16" x 1"
2	Locknut, 7/16"		

10" Models

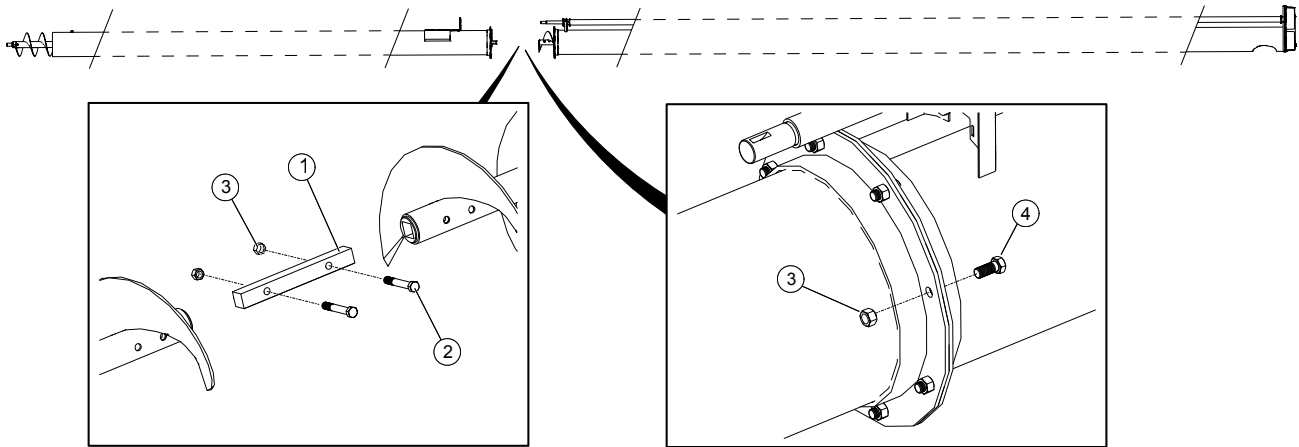

1	Flight Connector Shaft	3	Locknut, 7/16"
2	Bolt, 7/16" x 3"	4	Bolt, 7/16" x 1"

4.7. Install the Driveshaft

To use this section:

1. Locate and review the driveshaft layout drawing for the auger you are assembling in [Section 4.7.1 – Driveshaft Layout Drawings on page 28](#).
2. Follow the instructions in [Section 4.7.2 – Assemble the Driveshaft on page 33](#) while referring to the layout drawing for the auger you are assembling.

4.7.1 Driveshaft Layout Drawings

EMD/MD/Hydraulic – 41'/71'/76'

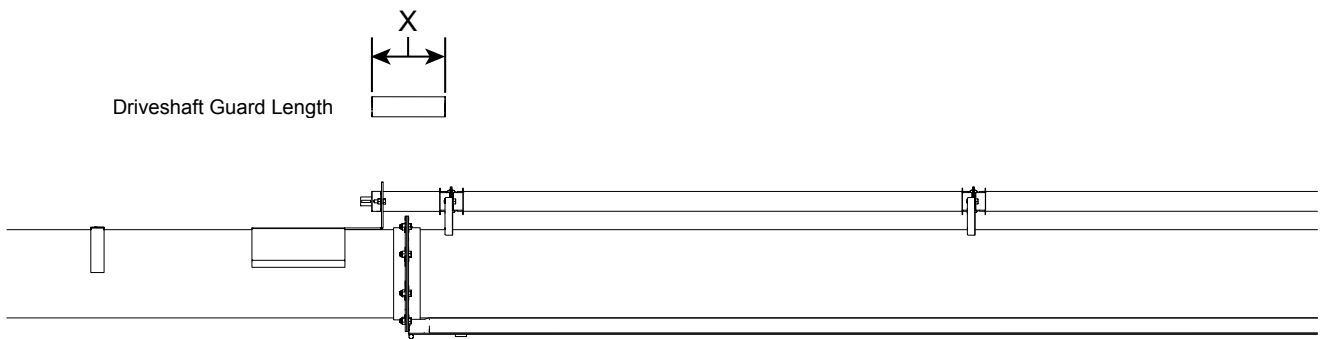

The lower driveshaft guard is not shipped on these augers, because it would make tube assembly more difficult. Guard lengths vary depending on model length.

PTO-SD – 31'

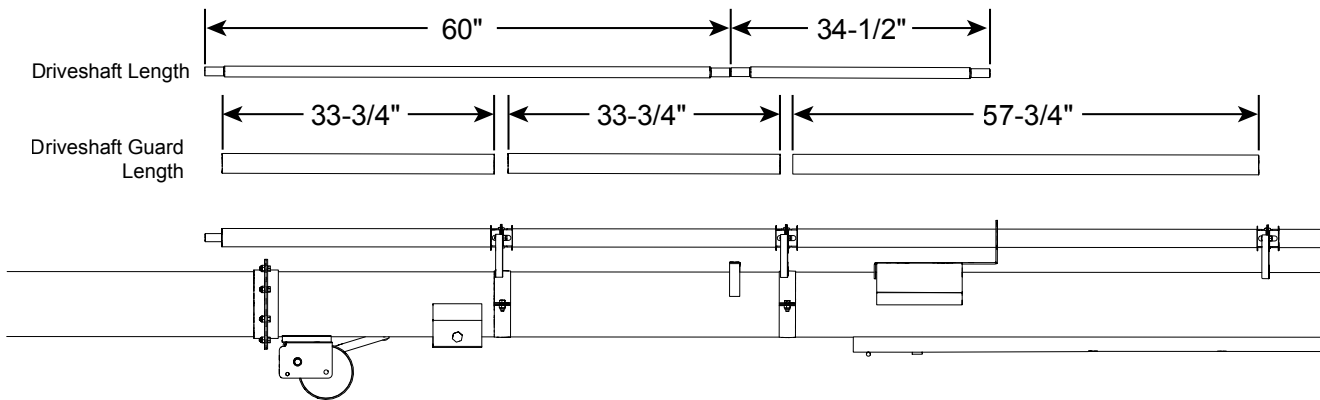

PTO-SD – 36'

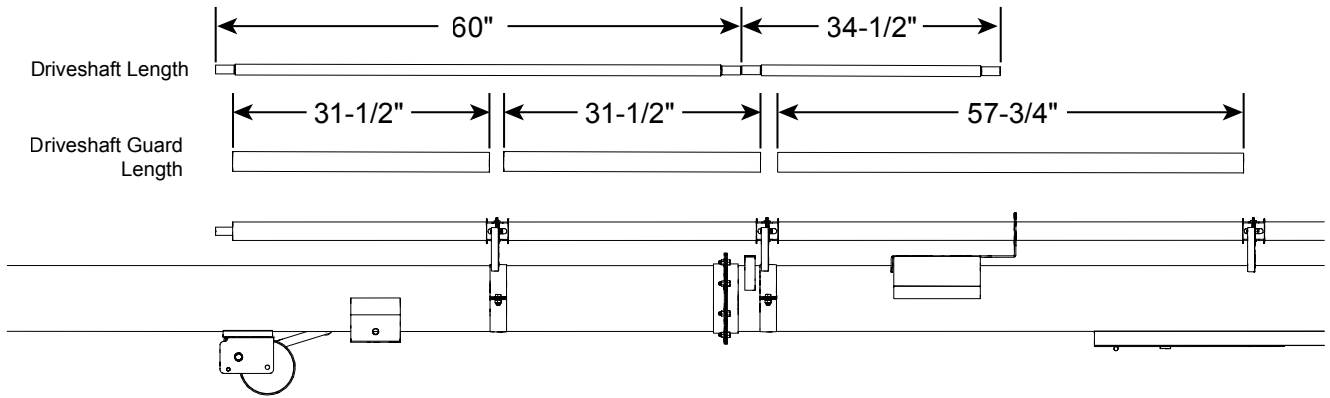

PTO-SD – 41'

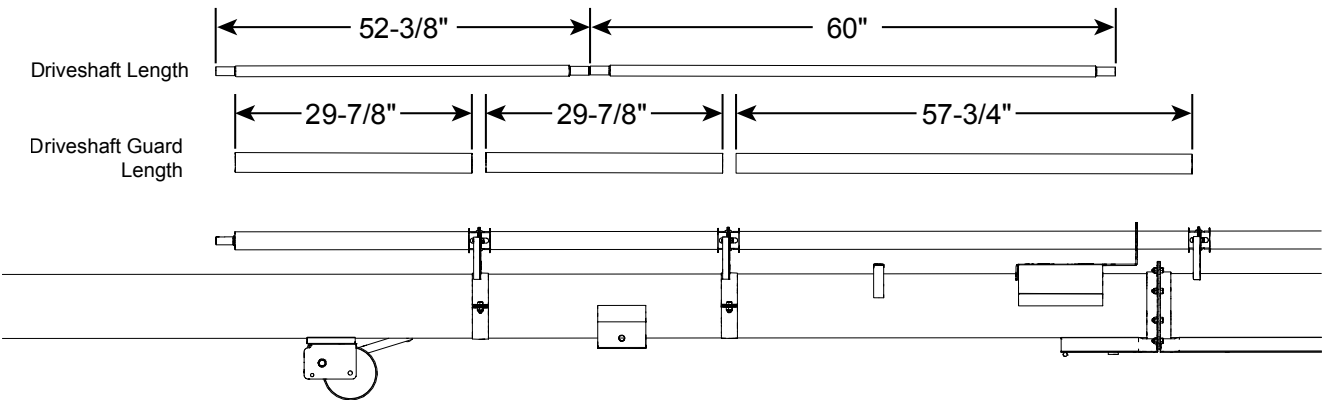

PTO-SD – 46'

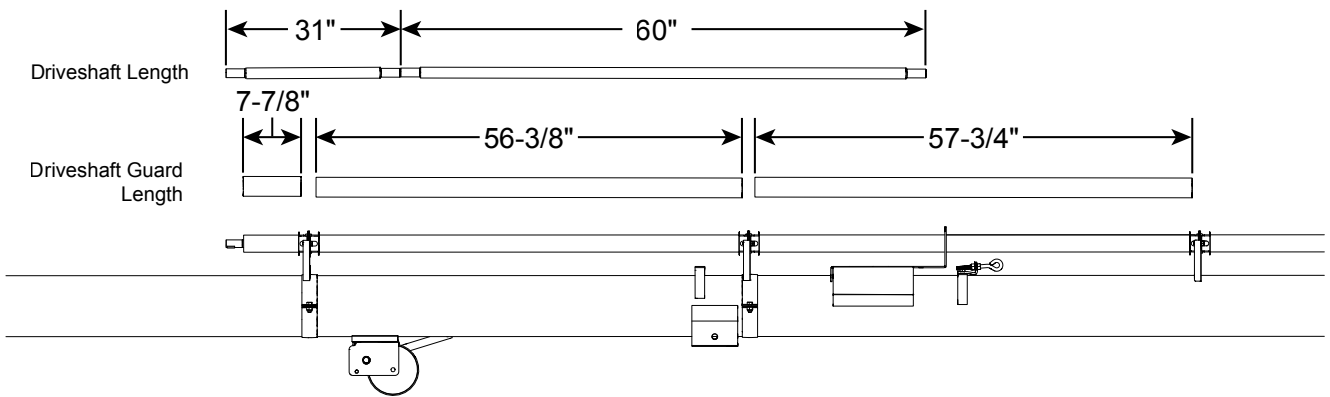

PTO-SD – 51'

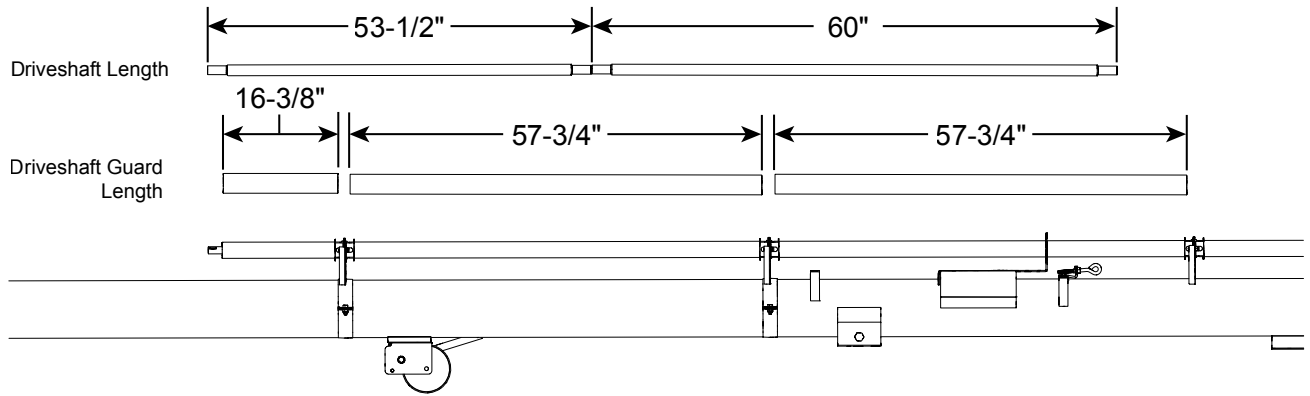

PTO-SD – 56'

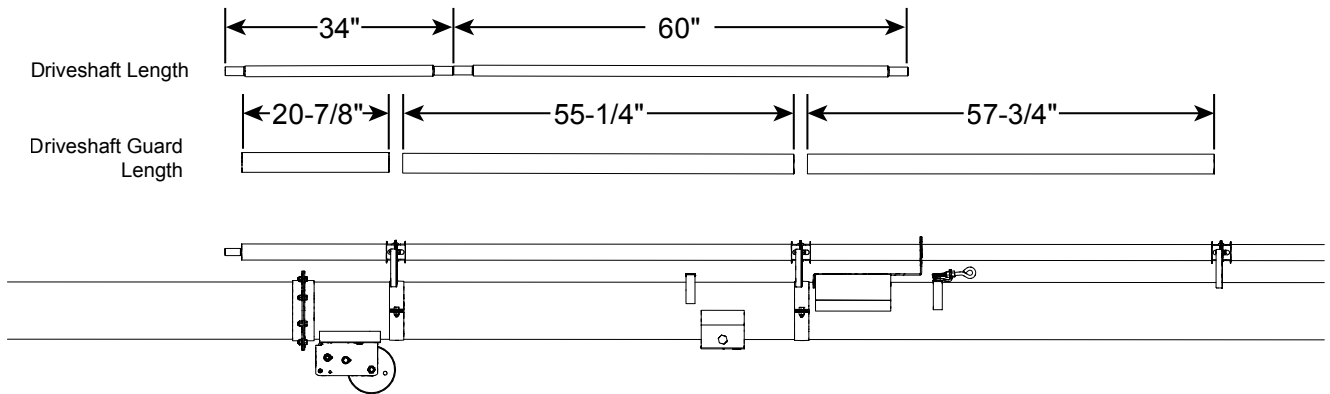

PTO-SD – 61'

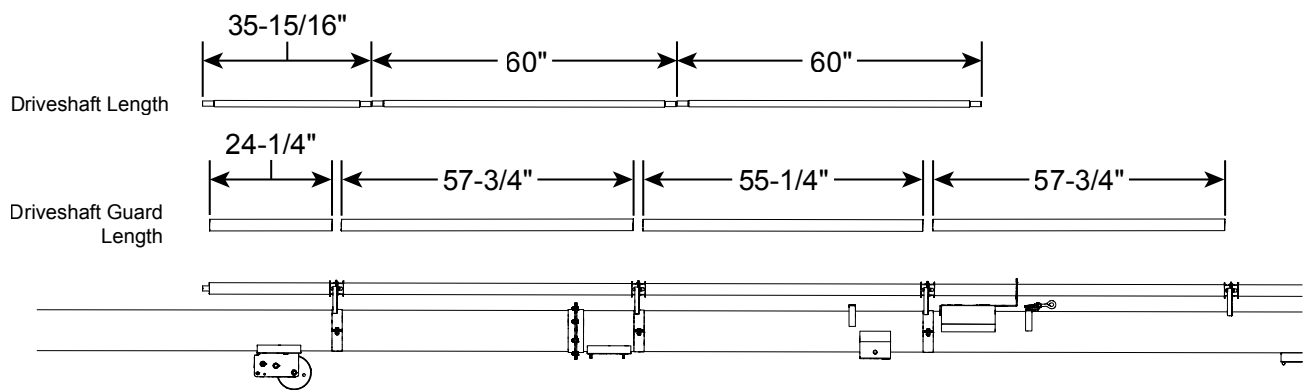

PTO-SD – 71'

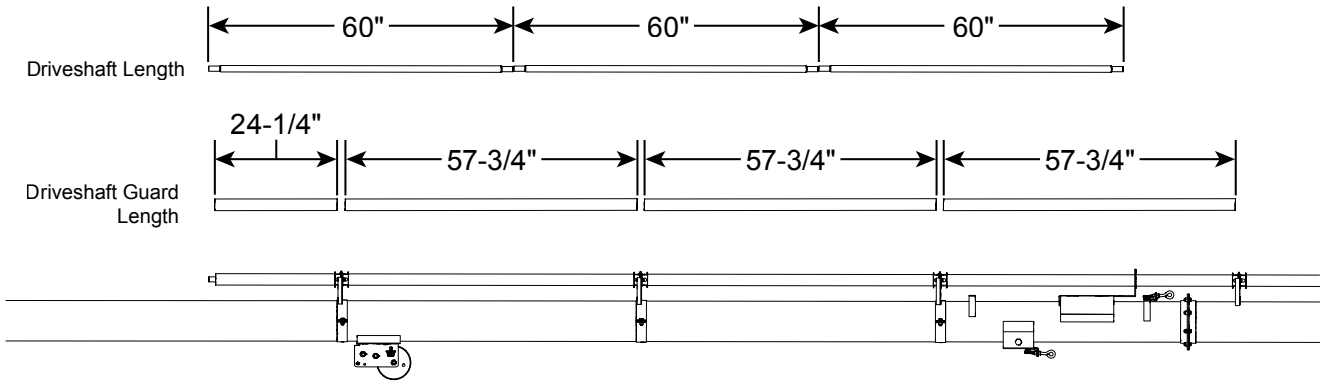

PTO-SD – 76'

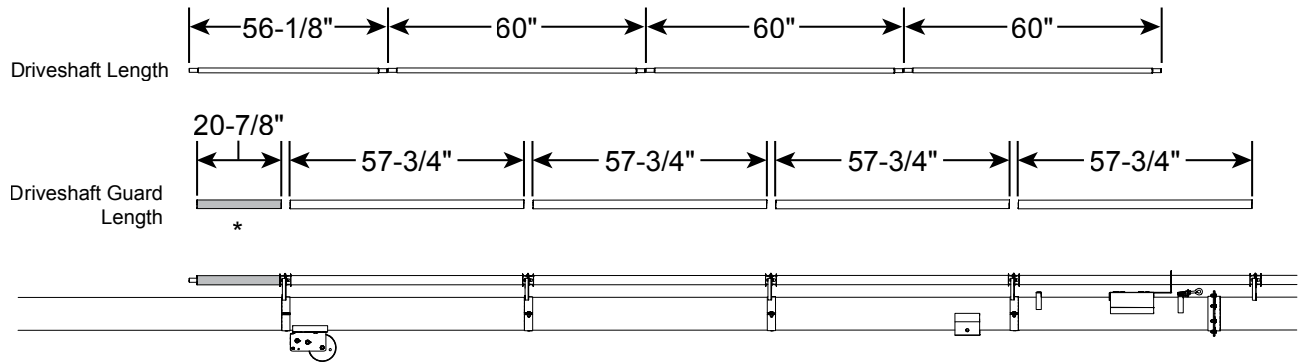

* Use the driveshaft guard that is shipped with the basic auger.

PTO-BD – 31' (RH side installation)

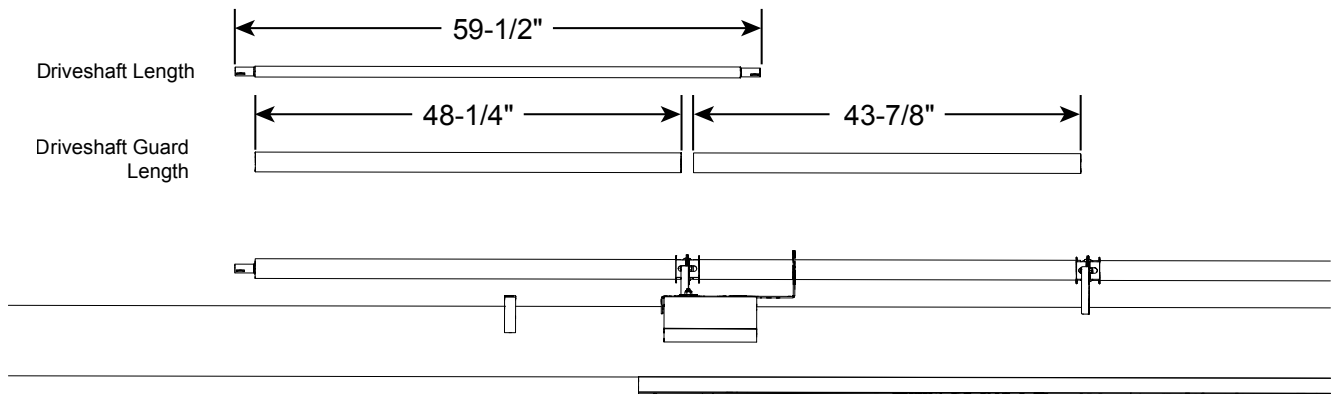

PTO-BD – 36' (RH side installation)

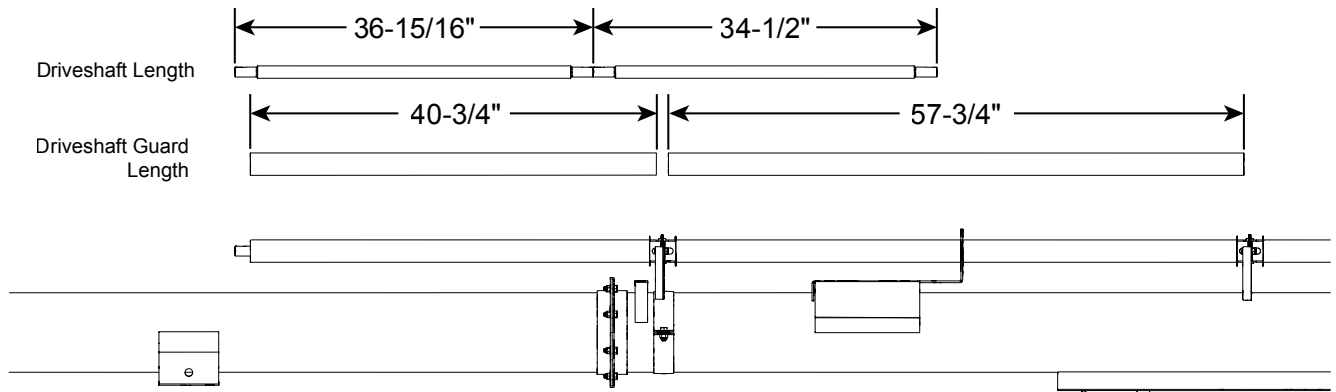

PTO-BD – 41' (RH side installation)

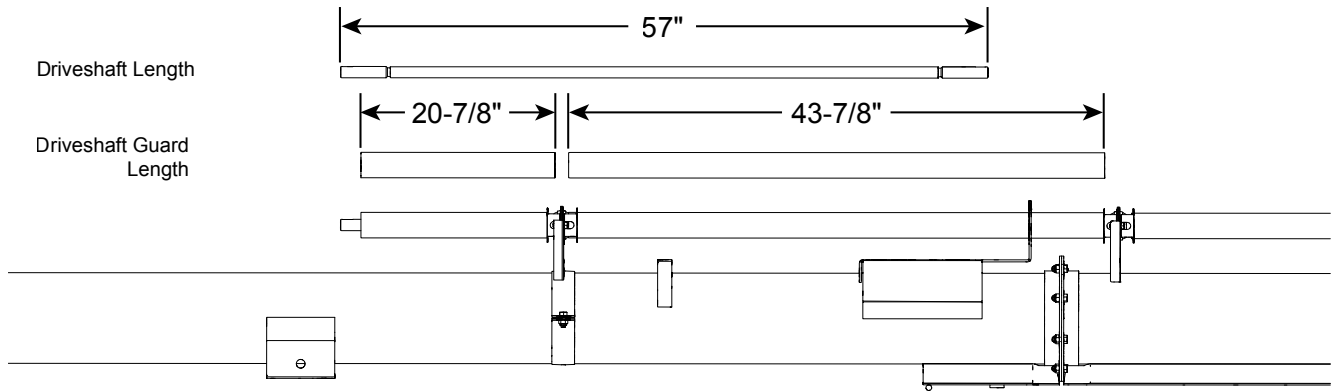

PTO-BD – 46' (RH side installation)

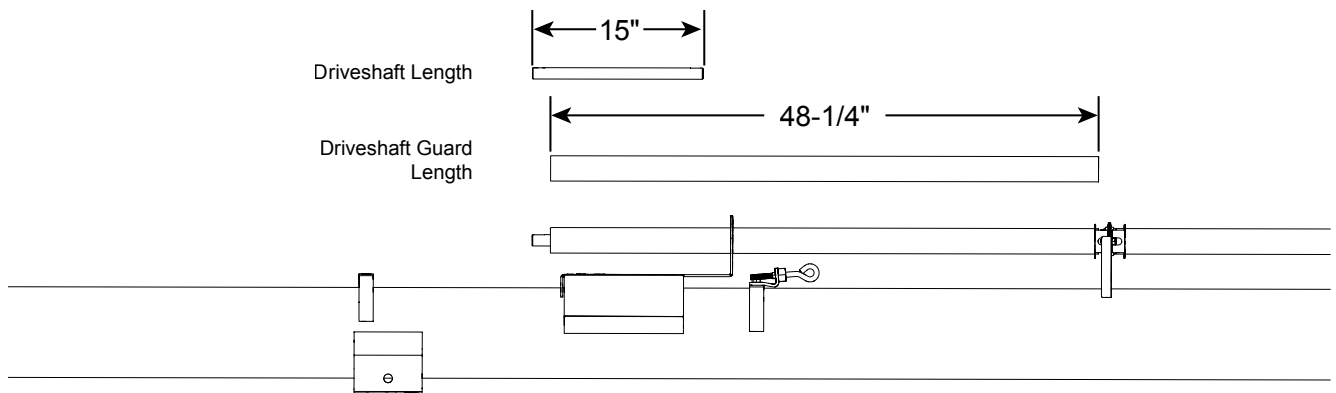

PTO-BD – 51' (RH side installation)

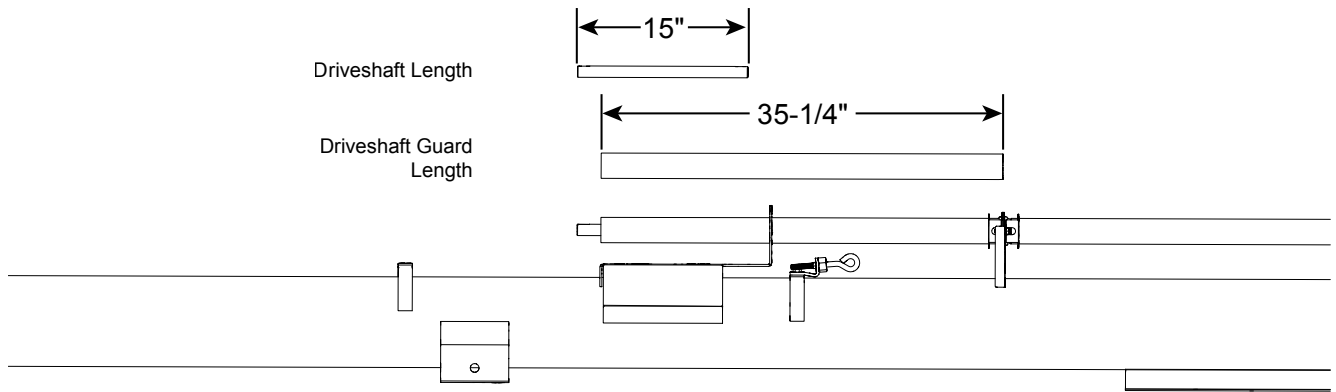

4.7.2 Assemble the Driveshaft

Overview

Step	Description
1	Remove the Hanger Bracket, and Lower Driveshaft Guard*
2	Connect the Driveshafts
3	Slide on the Driveshaft Guard
4	Install the Bearing
-	Repeat steps 2-4 until all lengths of driveshaft and driveshaft guard are installed

* Does not apply to EMD/MD/Hydraulic (41'/71'/76' Models)

Step 1: Remove the Hanger Bracket and Lower Driveshaft Guard

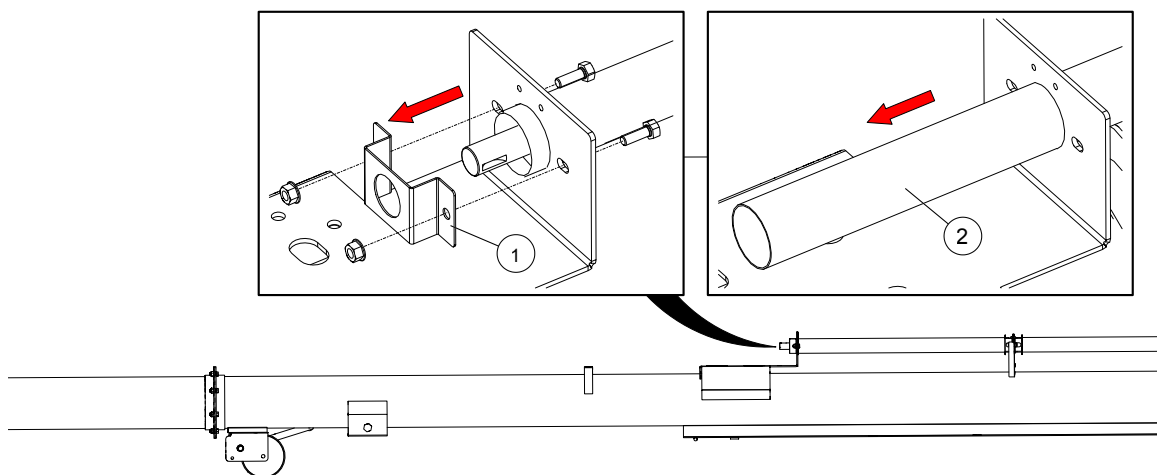

1	Hanger Bracket	2	Lower Driveshaft Guard
---	----------------	---	------------------------

Step 2: Connect the Driveshafts

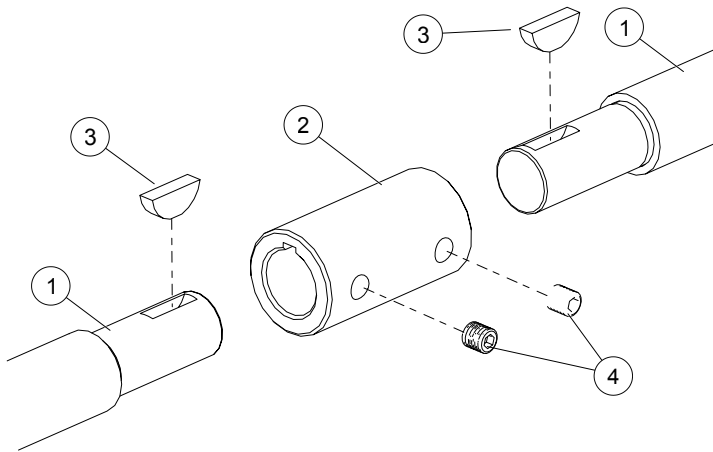

1	Driveshaft
2	Driveshaft Connector
3	Woodruff Key, 1/4" x 1"
4	Set Screw, 3/8" x 3/8"

Step 3: Slide on the Driveshaft Guard

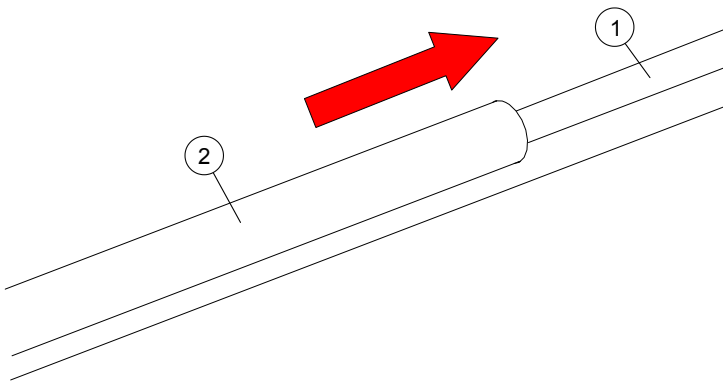

1	Driveshaft
2	New Driveshaft Guard (size according to layout)

Step 4: Install the Bearing

CLAMP-ON BEARING MOUNT

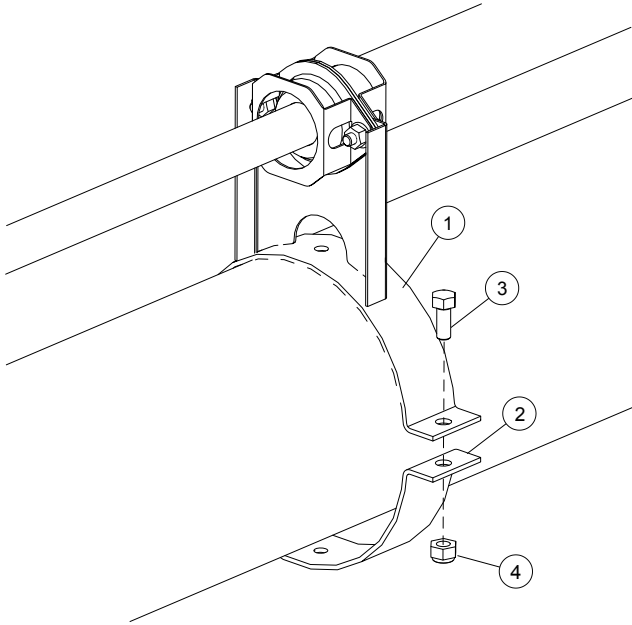

BEARING MOUNT ASSEMBLY

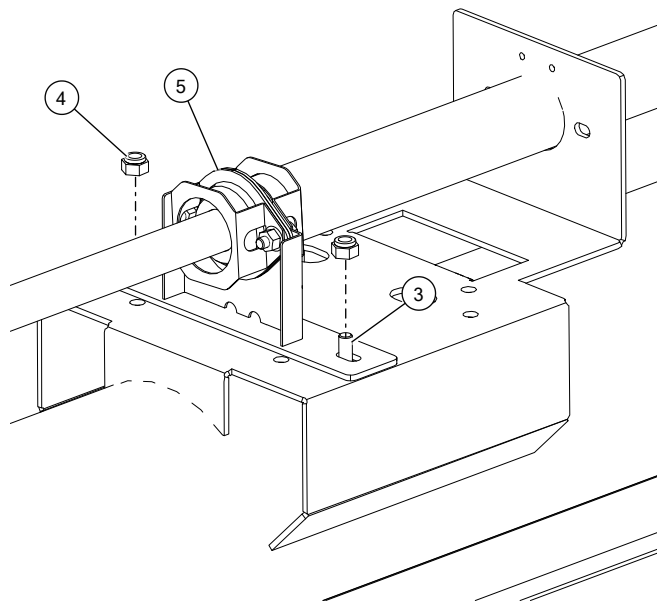

Assembly Notes:

- Slide the bearing up the driveshaft.
- If unable to slide the bearing up the driveshaft (eg. weldment in the way), disassemble the bearing from the clamp, bolt the two half clamps together, then reassemble the bearing on the driveshaft.
- The **Bearing Mount Assembly (5)** is only used for the **PTO-BD (31' Model)**.

1	Clamp-On Bearing Mount	4	Locknut, 7/16"
2	Half Clamp	5	Bearing Mount Assembly
3	Bolt, 7/16" x 1"		

DISASSEMBLED BEARING

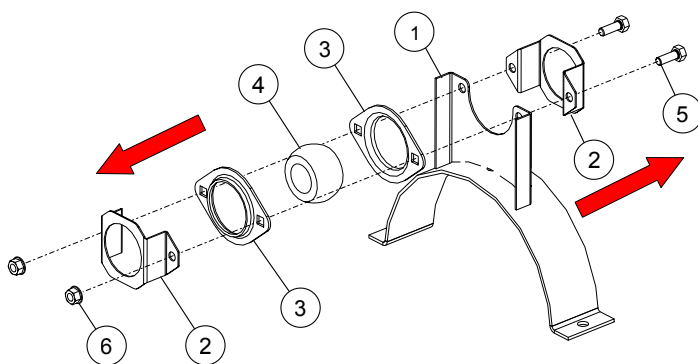

1	Clamp-On Bearing Mount Assembly
2	Flange Bearing Hanger Bracket
3	Flange, 1-1/4"
4	Wood Bearing, 1-1/4"
5	Bolt, 3/8" x 1"
6	Whiznut, 3/8"

4.8. Install the Track Stops

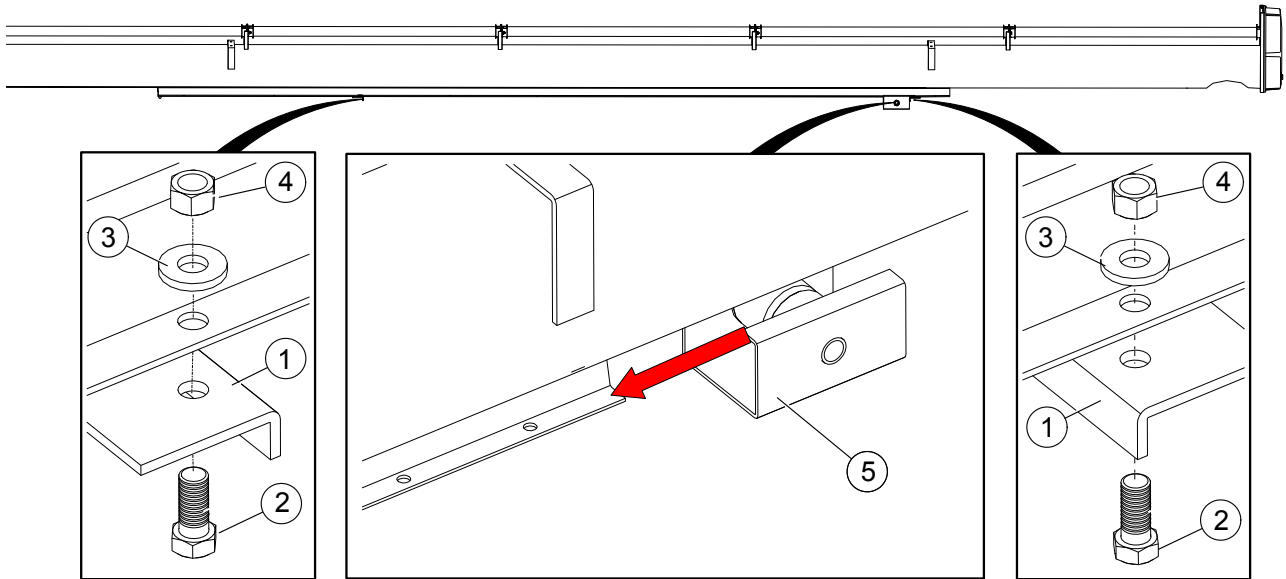

Assembly Notes:

- Slide Track Shoe onto track before attaching upper track stop.
- A lower track stop is only required for 56'/61'/71' augers and augers with the MD drive option.

1	Track Stop	4	Locknut, 7/16"
2	Bolt, 7/16" x 1"	5	Track Shoe
3	Track Washer, 7/16"		

Track Stop Locations (31' – 41')

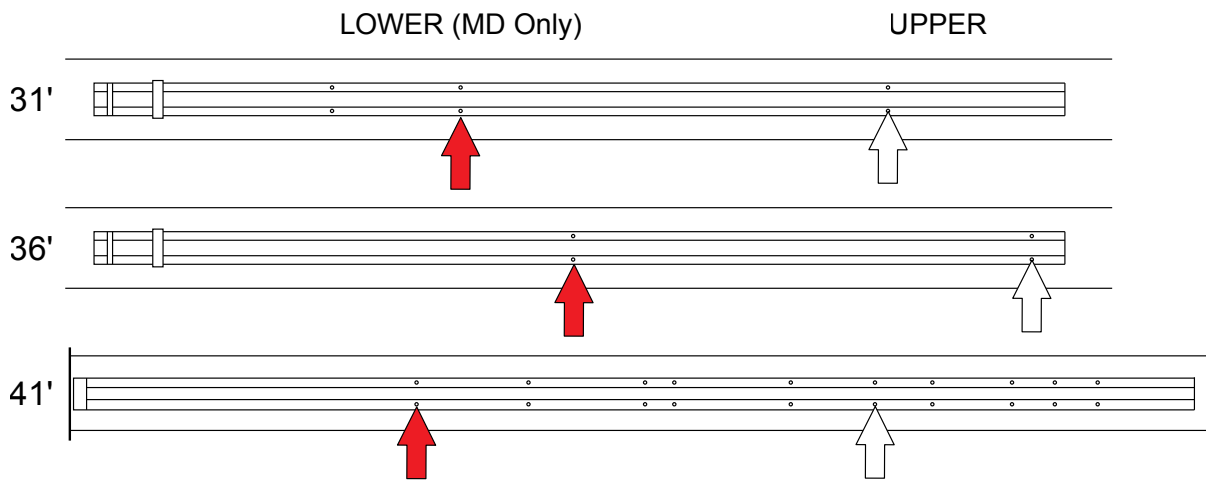

Upper Track Stop Locations (46' – 76')

UPPER TUBES

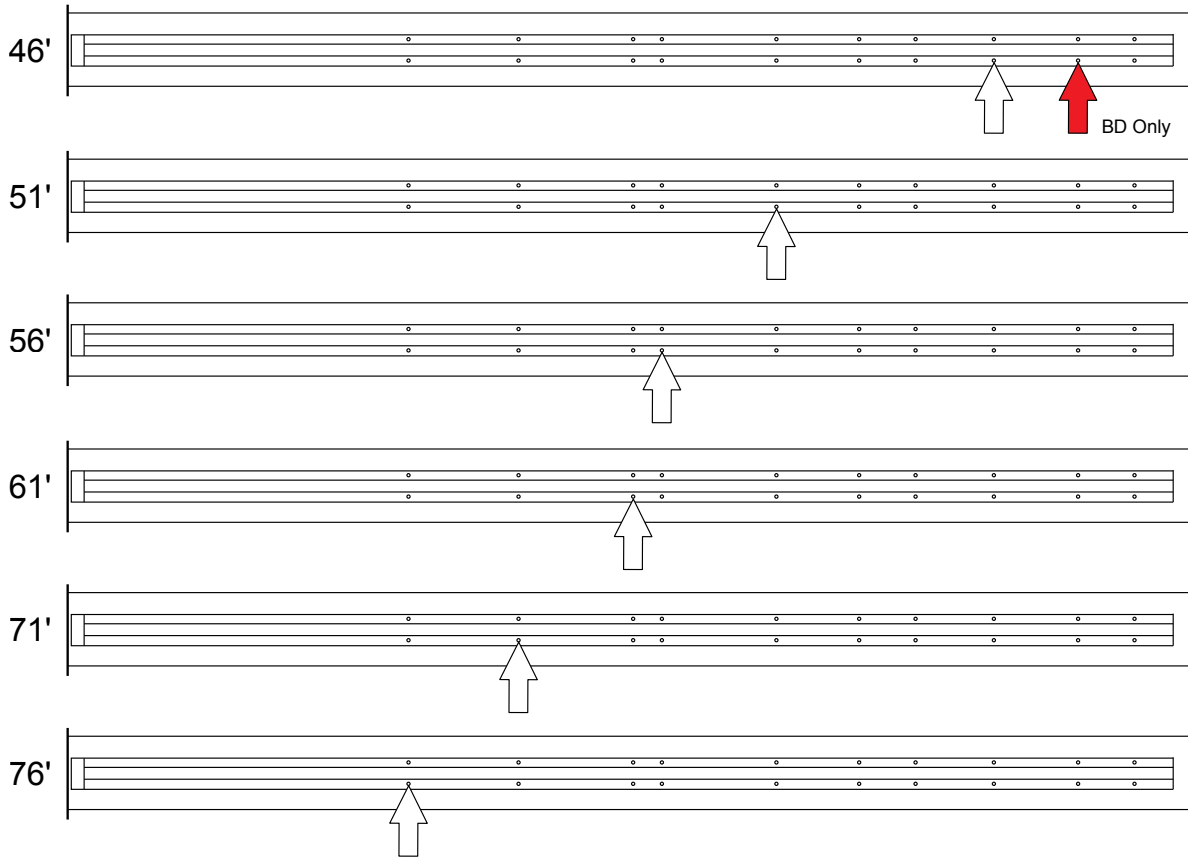

Lower Track Stop Locations (56' – 71')

MIDDLE TUBES

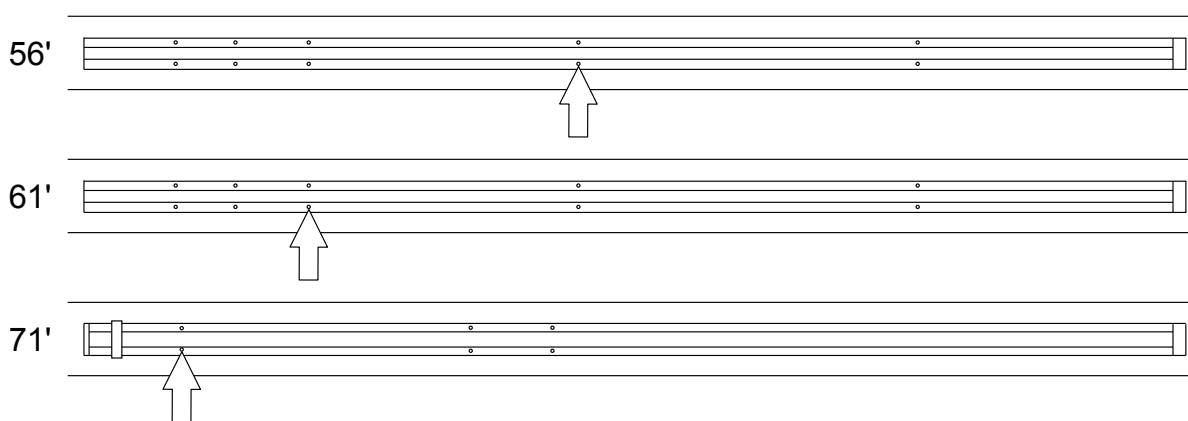

4.9. Install the Spout

8" Models

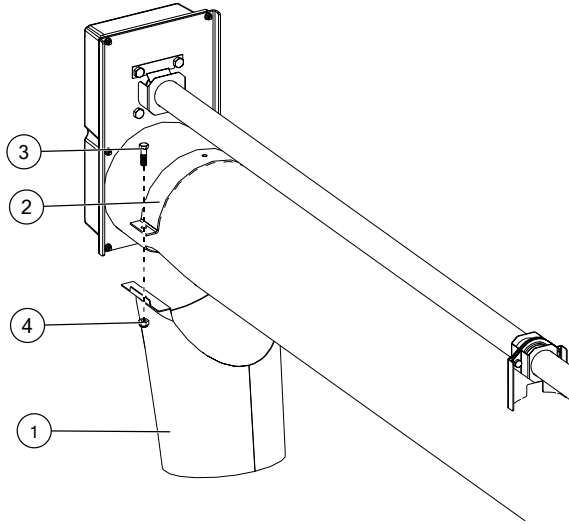

1	Spout
2	Half Clamp
3	Bolt, 7/16" x 1-1/2"
4	Locknut, 7/16"

10" Models

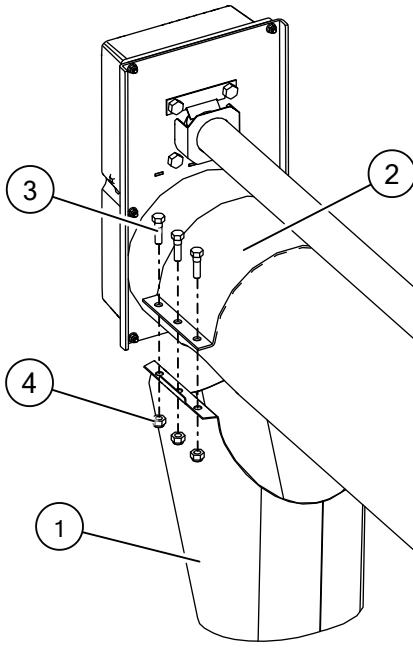

1	Spout
2	Wide Half Clamp
3	Bolt, 7/16" x 1-1/2"
4	Locknut, 7/16"

4.10. Install the Sprocket Head Gearing

This section only applies to PTO-SD options (540 rpm).

Installing the Sprocket Head Gearing

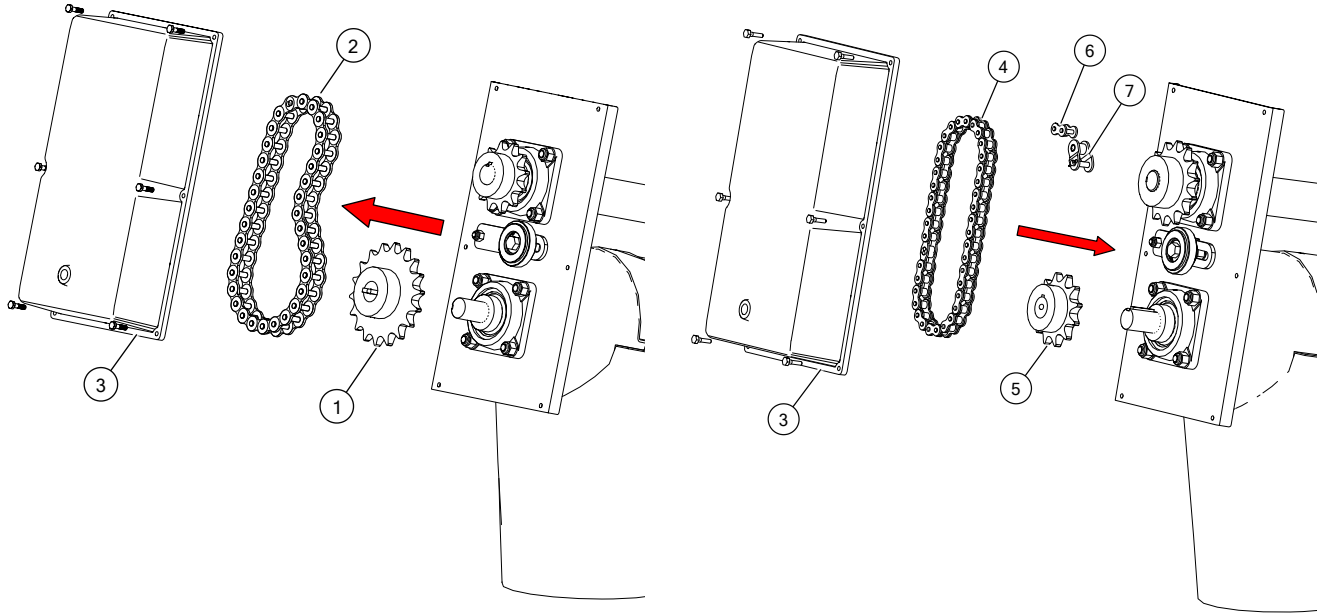

Assembly Notes:

- This step is only required when using a 540 RPM tractor.
- Remove the head cover, upper drive chain and bottom sprocket.
- Install a new sprocket to the bottom shaft.
- Install a new chain using a connector link and offset link.
- Re-install the existing head cover.

1	Sprocket, 80B18 x 1 (8" only)	5	Sprocket, 80B12 x 1 (8" only)
	Sprocket, 80B19 x 1-1/4 (10" only)		Sprocket, 80B12 x 1-1/4 (10" only)
2	Chain, #80 x 31P	6	Connector Link, #80
3	Head Cover	7	Offset Link, #80
4	Chain, #80 x 27P		

4.11. Add Grease to Head Cover

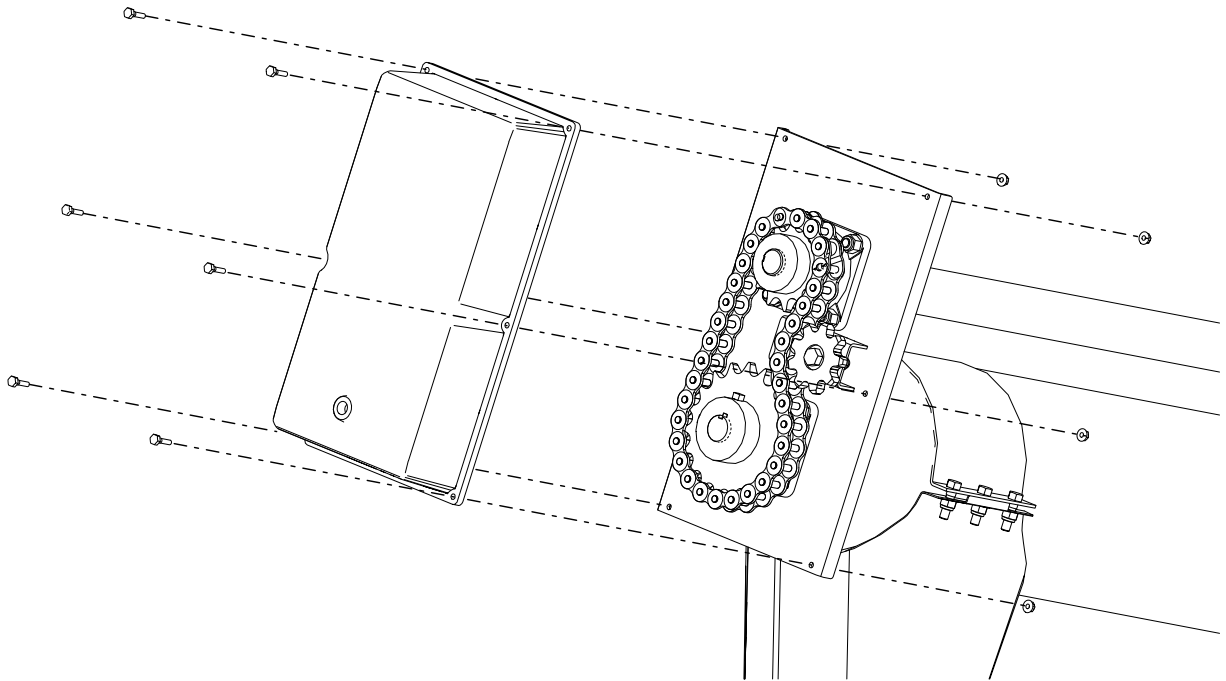

1. Remove the head cover from the discharge end.
2. Fill the head cover half full of grease.
3. Lubricate the chain.
4. Re-install the head cover.

4.12. Install the Intake Cage

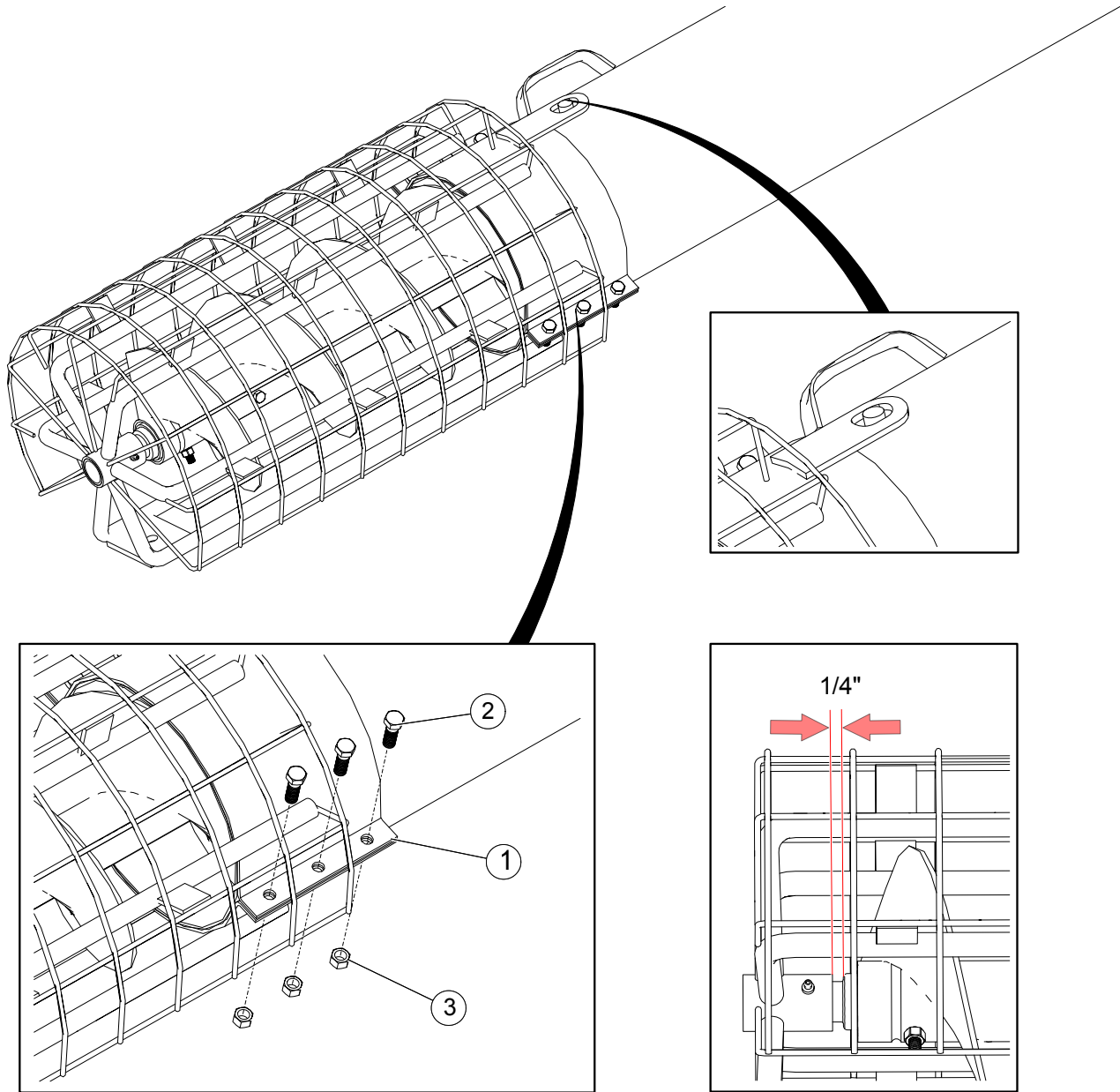

Assembly Notes:

- Ensure the slot on intake cage engages the retention pin on lower tube.
- Maintain a 1/4" clearance between the bushing and the end of the flight.

1	Intake Cage	3	Locknut, 7/16"
2	Bolt, 7/16" x 1-1/4"		

4.13. Install the Hitch

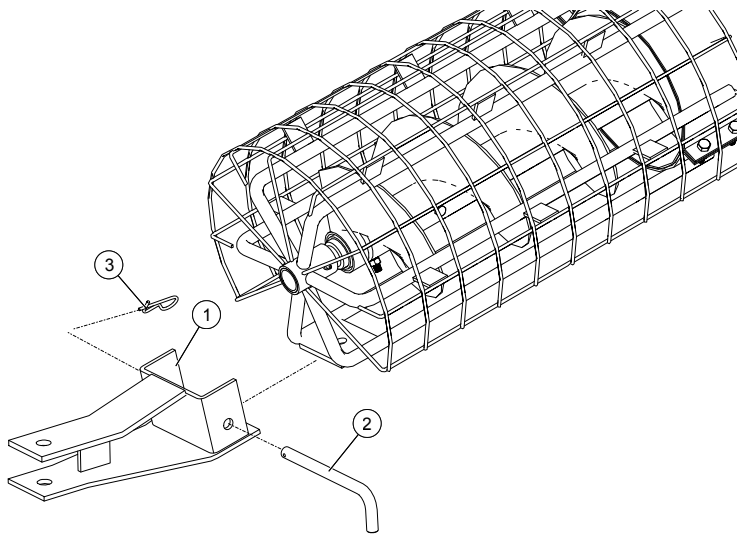

1	Clevis Hitch
2	Clevis Pin
3	Grip Clip

4.14. Install the Lift Cable

1. Attach the cable to the cable attach rod welded to the bottom of the track by wrapping it around the rod 1.5 times and doubling-back about 7" (18 cm) of cable.
2. Secure the cable in place by installing and tightening two cable clamps.
 - a. Apply first clamp 6" (15 cm) from the cable loop with the u-bolt over the dead end. Live end rests in clamp saddle. Tighten nuts evenly to recommended torque of 15 ft·lb.
 - b. Apply second clamp as close to loop as possible with the u-bolt over the dead end. Live end rests in clamp saddle. Tighten nuts evenly to recommended torque of 15 ft·lb.
3. Run cable between the track stop and the auger tube.
4. Thread the cable over and around the track shoe. Make certain it is properly seated in the cable groove.
5. Tape down the loose end of the cable so it can be connected to the winch.

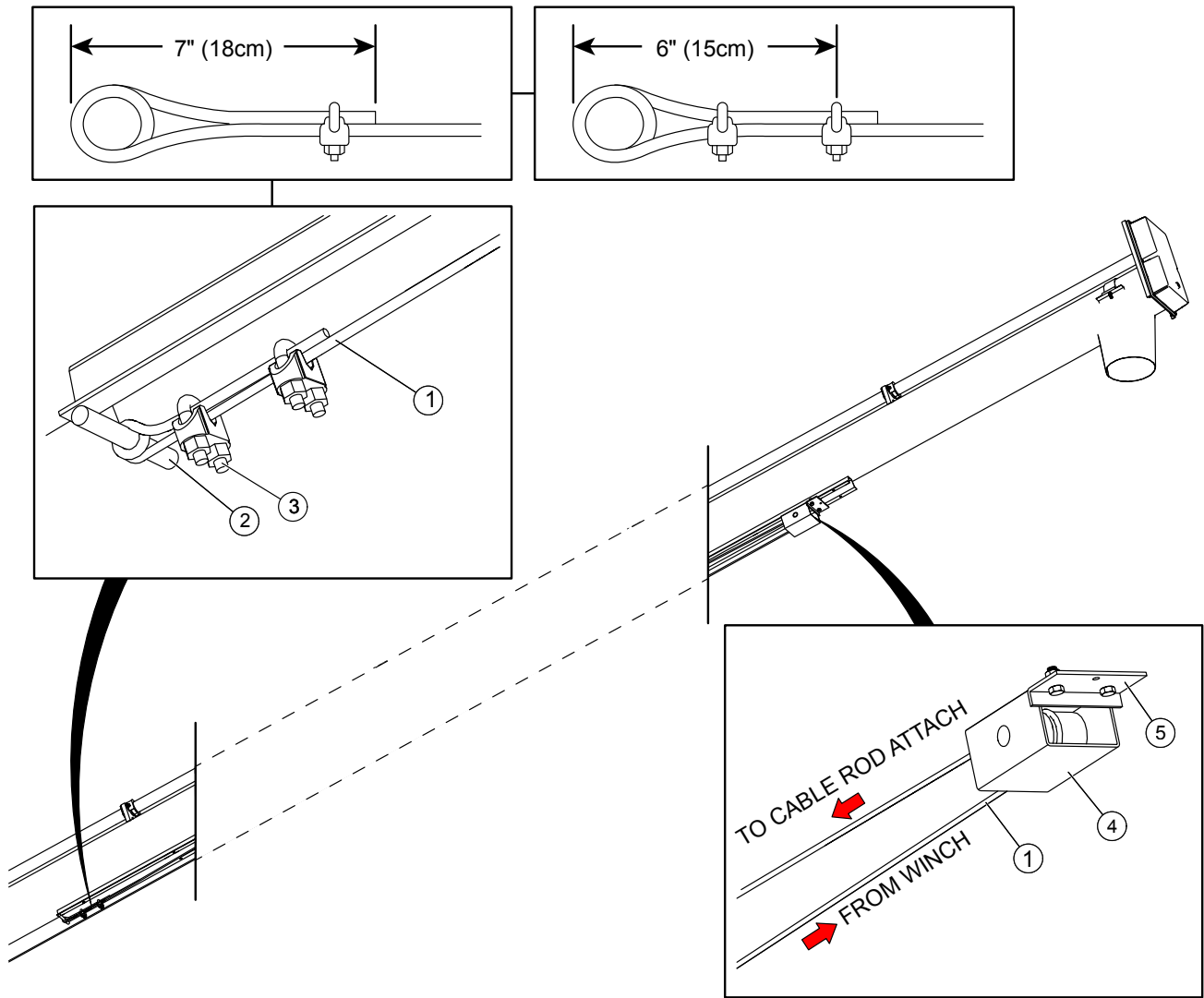

Assembly Notes:

- Torque the cable clamps to 15 ft·lb
- The Lift Cable installation can be completed after the manual winch is installed.

1	Lift Cable, 1/4"	4	Track Shoe
2	Cable Attach Rod	5	Track Stop
3	Cable Clamp, 1/4"		

4.15. Install Truss Towers and Truss Cable

For 46'–76' Models Only

4.15.1 Install Truss Towers

46'/51'/56'/61' Models

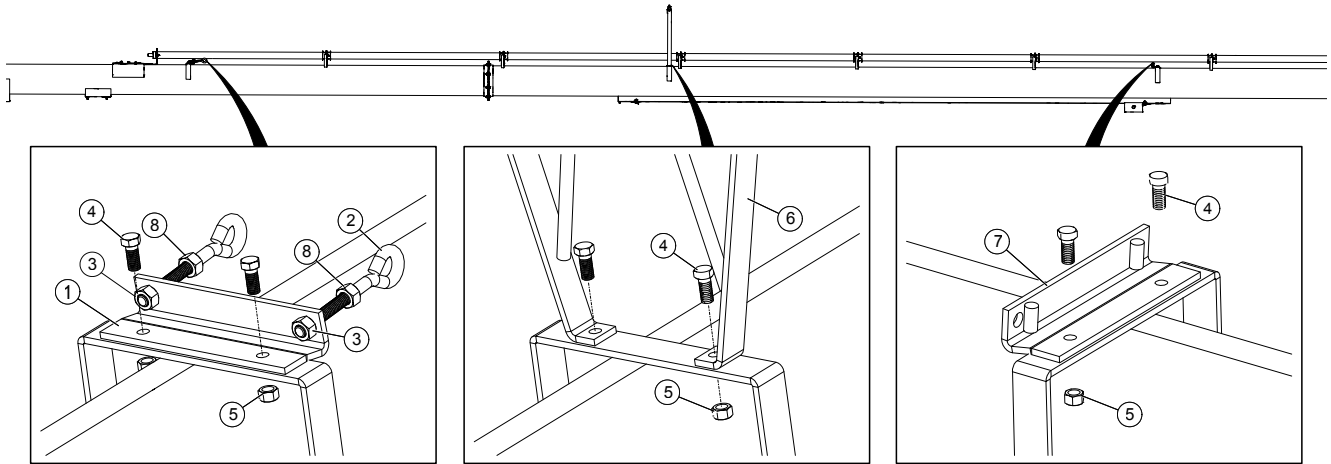

Assembly Notes:

- 46' & 51' Models require one truss tower
- 56' & 61' Models require two truss towers

1	Truss Cable Anchor Bracket, Bottom	5	Locknut, 7/16"
2	Eyebolt, 1/2"	6	Truss Bracket
3	Locknut, 1/2"	7	Truss Cable Anchor (with welded rods)
4	Bolt, 7/16" x 1"	8	Hex Nut, 1/2"

71'/76' Models

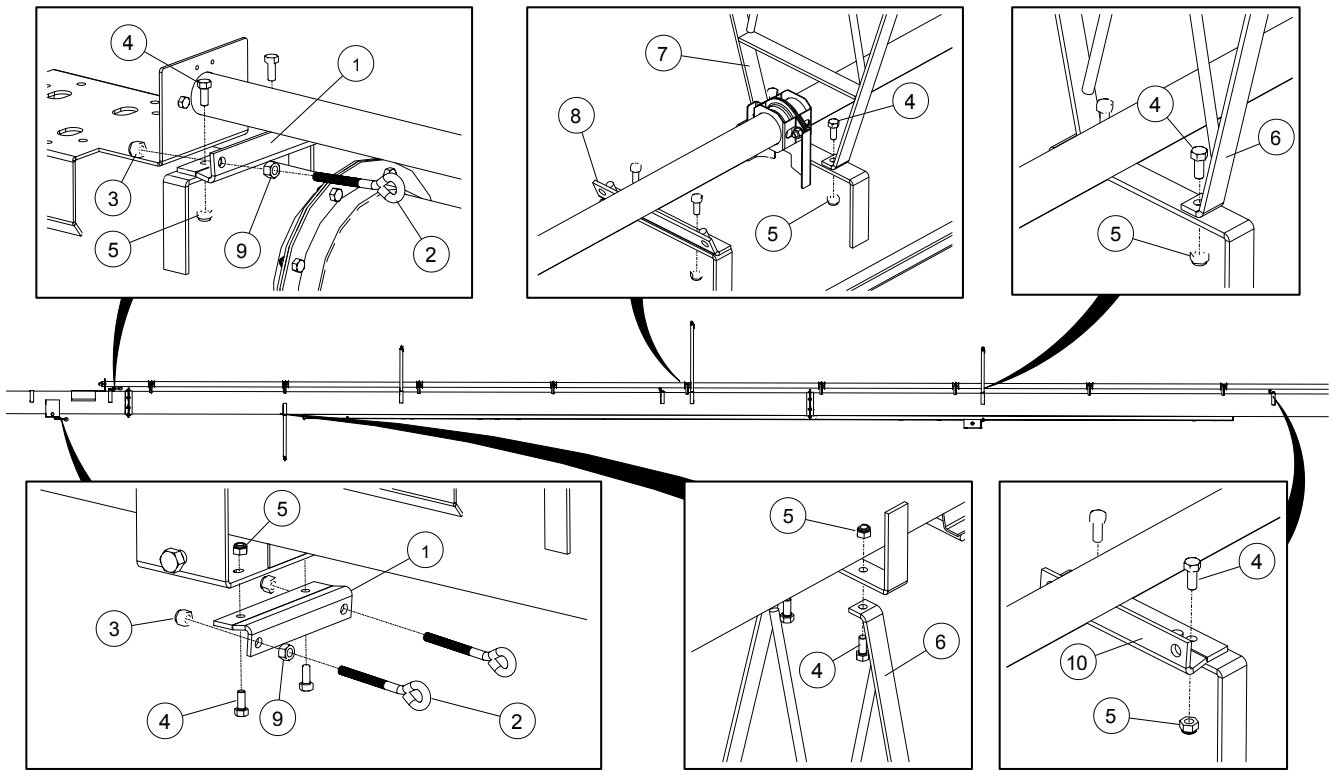

1	Truss Cable Anchor Bracket, Bottom	6	Truss Bracket
2	Eyebolt, 1/2"	7	Large Truss Bracket
3	Locknut, 1/2"	8	Wide Truss Cable Anchor (with welded rods)
4	Bolt, 7/16" x 1"	9	Hex Nut, 1/2"
5	Locknut, 7/16"	10	Truss Cable Anchor (with welded rods)

4.15.2 Install Truss Cable

Cable Path

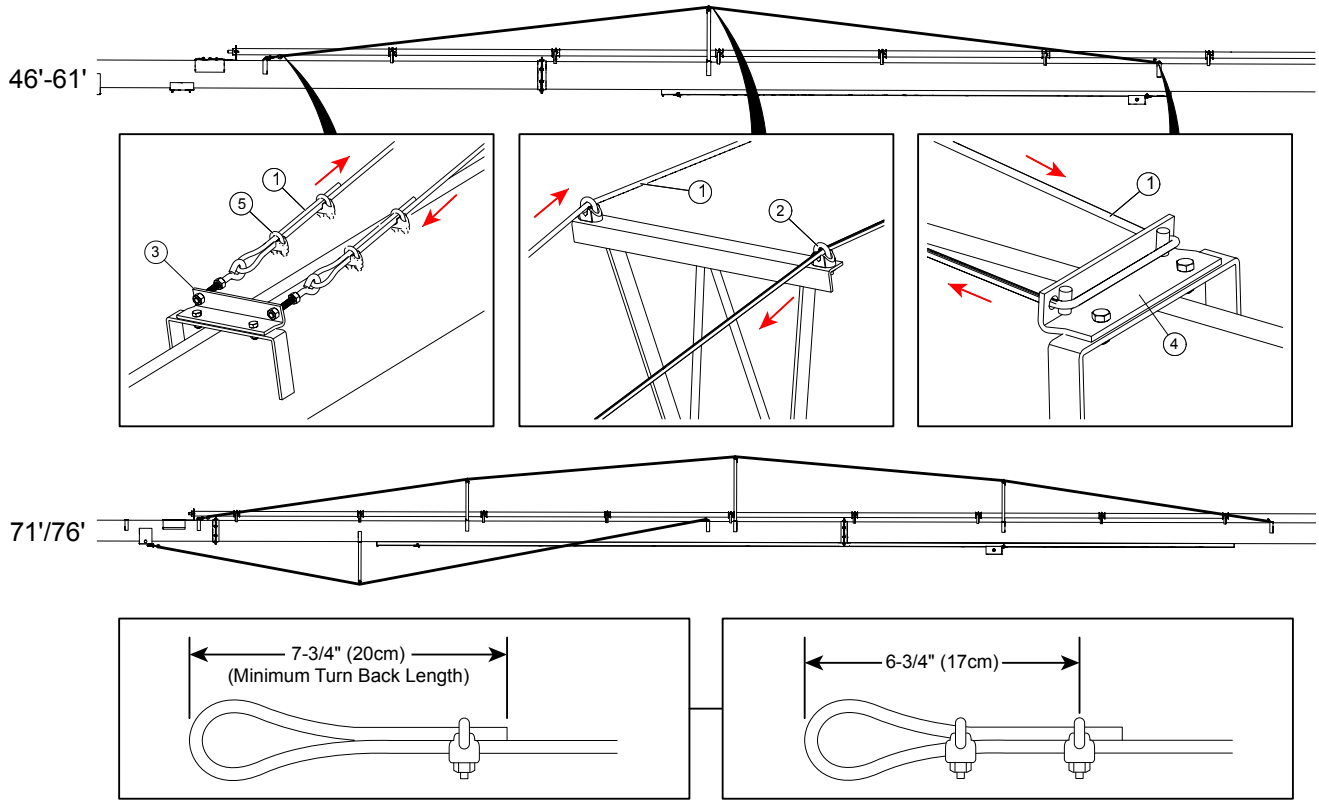

1	Cable, 5/16"	4	Truss Cable Anchor (with welded rods)
2	Cable Clamp, 1/4"	5	Cable Clamp, 5/16"
3	Truss Cable Anchor Bracket, Bottom		

Anchor the Cable

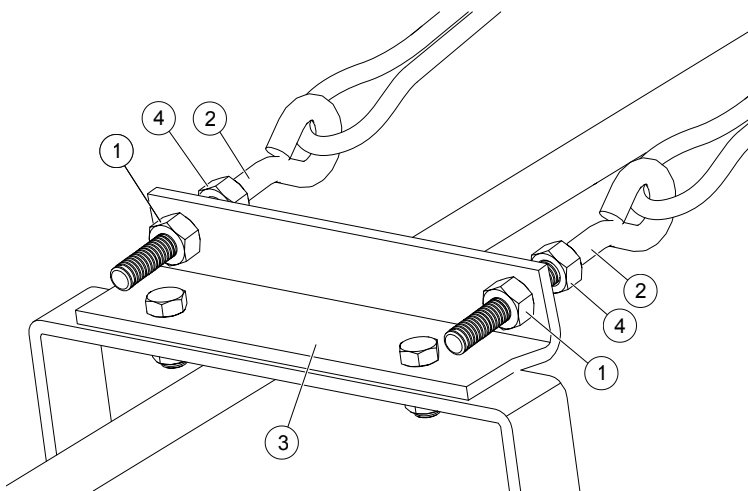

1	Locknut, 1/2"
2	Eyebolt, 1/2"
3	Truss Cable Anchor, Bottom
4	Hex Nut, 1/2"

1. Thread truss cable through eyebolt and double-back 7-3/4" (20 cm) of cable. Secure the cable in place by installing and tightening two 5/16" cable clamps.
 - a. Apply the first clamp 6-3/4" from the cable loop with the u-bolt over the dead end. The live end rests in clamp saddle. Tighten nuts firmly but do not fully tighten.
 - b. Apply the second clamp as close to the loop as possible in the same orientation as the first clamp. The live end rests in clamp saddle. Apply tension and tighten nuts firmly but do not fully tighten.
2. Tighten the locknuts evenly to take the remaining slack out of the truss cable.

Important

Take slack out of the truss cable only (DO NOT tension the cable). Tension in the cable will cause the auger to droop at the flange when in the lowered position.

3. Check for proper side-to-side alignment.
4. Tighten all cable clamps to the recommended torque.

Cable Clamp	Nut Torque
1/4"	15 ft·lb
5/16"	20 ft·lb

5. Tighten the hex nuts against the cable anchor bracket.

4.16. Install the Gearbox and Gearbox Brackets

4.16.1 EMD/MD

Installing the EMD/MD Gearbox

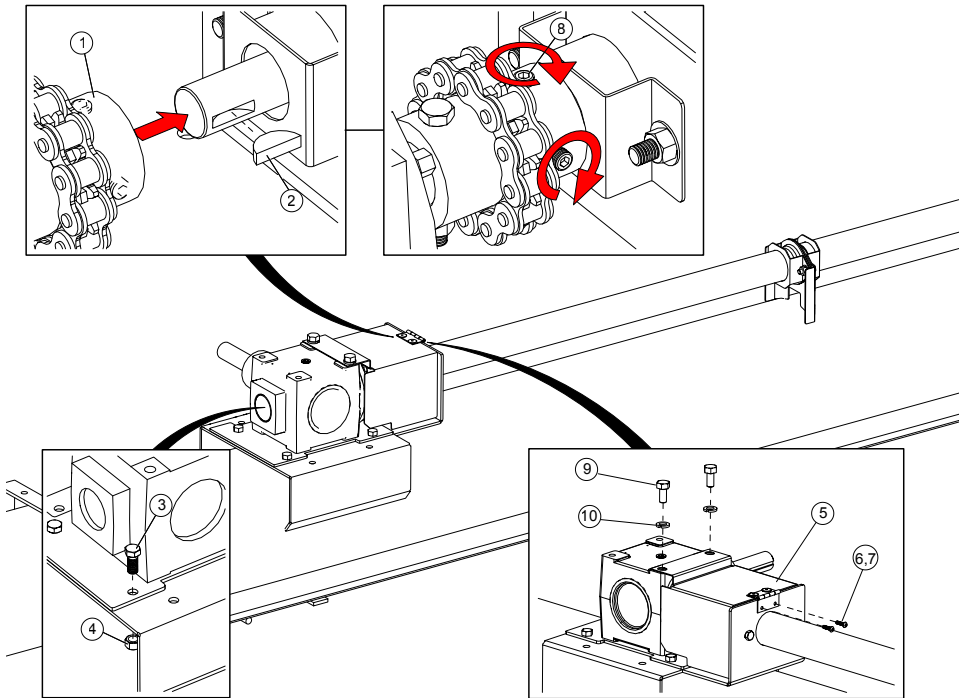

Assembly Notes:

- Check the gearbox oil level; gearbox should be half full. Use only EP90 lube oil and fill to HALF FULL only.
- The ends of the gearbox shaft and the driveshaft should be flush with the inside of the chain coupler sprockets.

If the driveshaft is too long or too short, do the following:

- If the driveshaft is too long, take up the extra length in the driveshaft connector(s).

Note

There may be more than one driveshaft connector in the drive system.

- If the driveshaft is too short, remove the headcover, chain, sprocket, and lock collar at the top of the upper tube to adjust the two driveshafts.

1	Gearbox Assembly	6	Bolt, #10 x 3/4"
2	Woodruff Key, 1/4" x 1"	7	Locknut, #10
3	Bolt, 7/16" x 1"	8	Set Screw, 3/8" x 3/8"
4	Locknut, 7/16"	9	Bolt, 1/2" x 1"
5	Chain Coupler Guard Assembly	10	Lock Washer, 1/2"

Installing the Gearbox Brackets (MD Only)

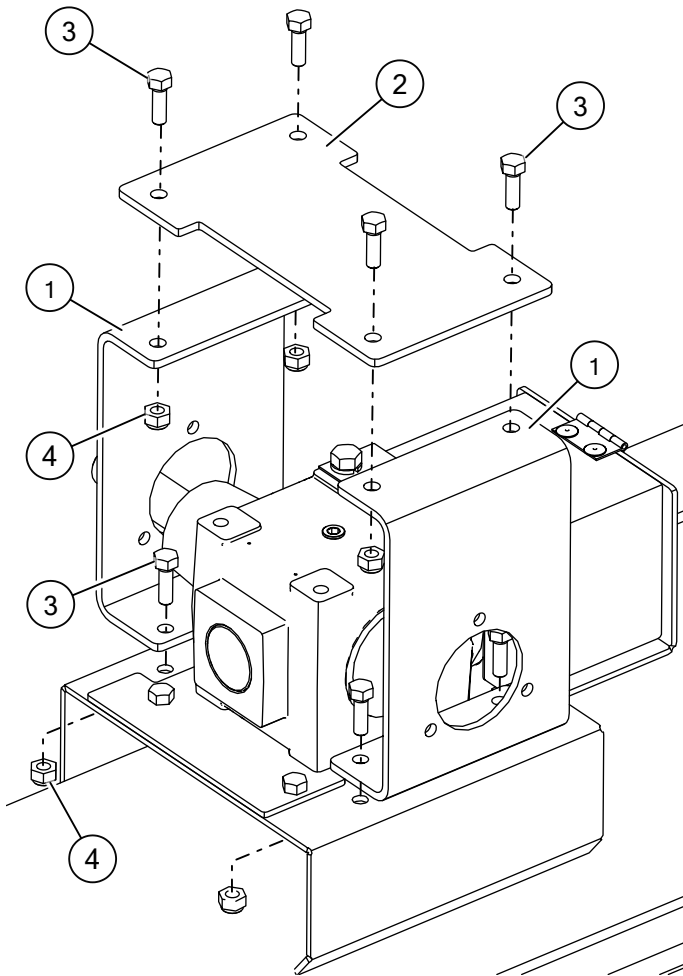

1	Connect Bracket
2	Top Cover Bracket
3	Bolt, 7/16" x 1-1/4"
4	Locknut, 7/16"

4.16.2 PTO-SD

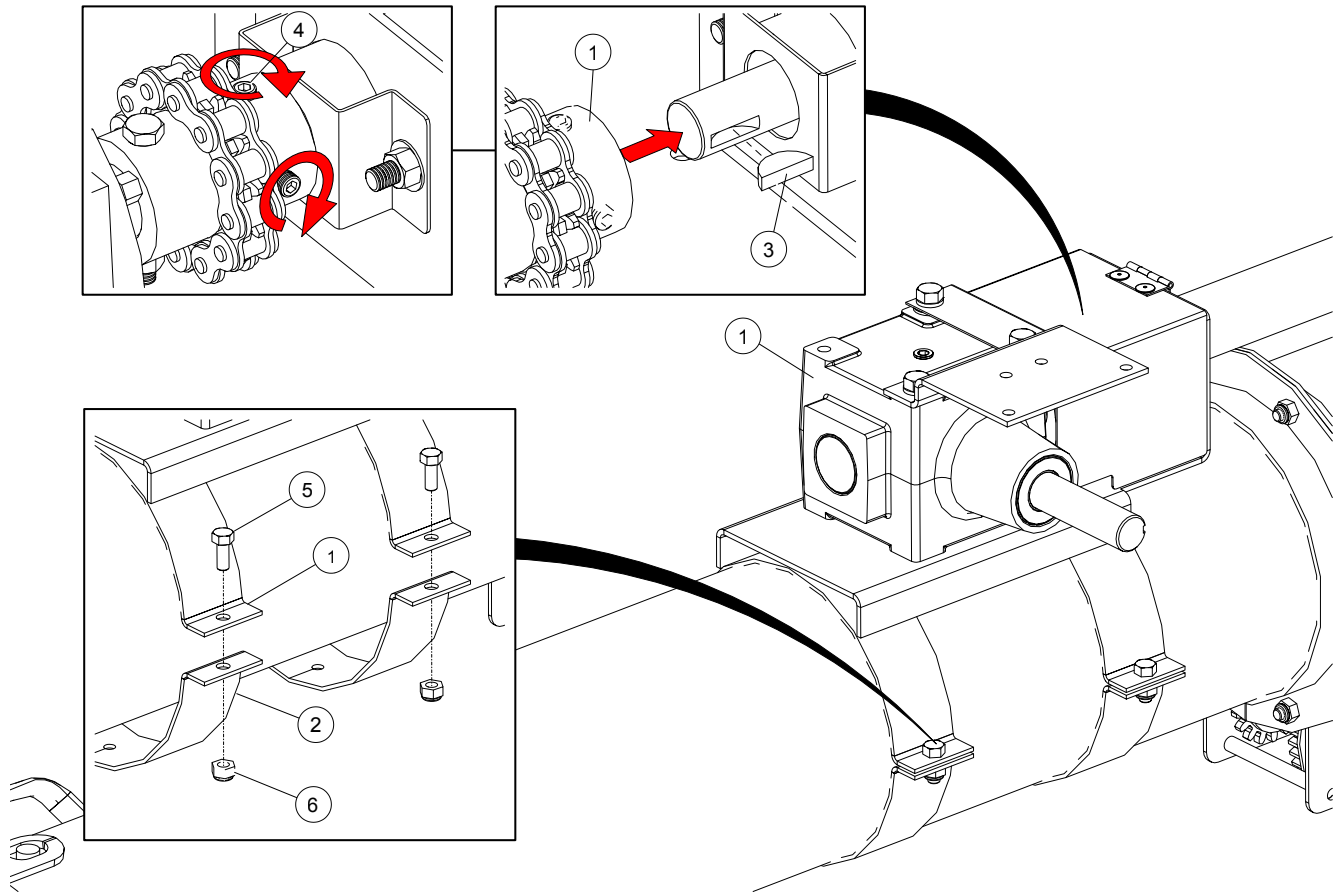

Assembly Notes:

- Check the gearbox oil level; gearbox should be half full. Use only EP90 lube oil and fill to HALF FULL only.
- The ends of the gearbox shaft and the driveshaft should be flush with the inside of the chain coupler sprockets.

1	Clamp-On Gearbox Assembly	4	Set Screw, 3/8" x 3/8"
2	Half Clamp	5	Bolt, 7/16" x 1"
3	Woodruff Key, 1/4" x 1"	6	Locknut, 7/16"

4.16.3 PTO-BD

Installing the Gearbox Mount

31'/36'/41' Models Only

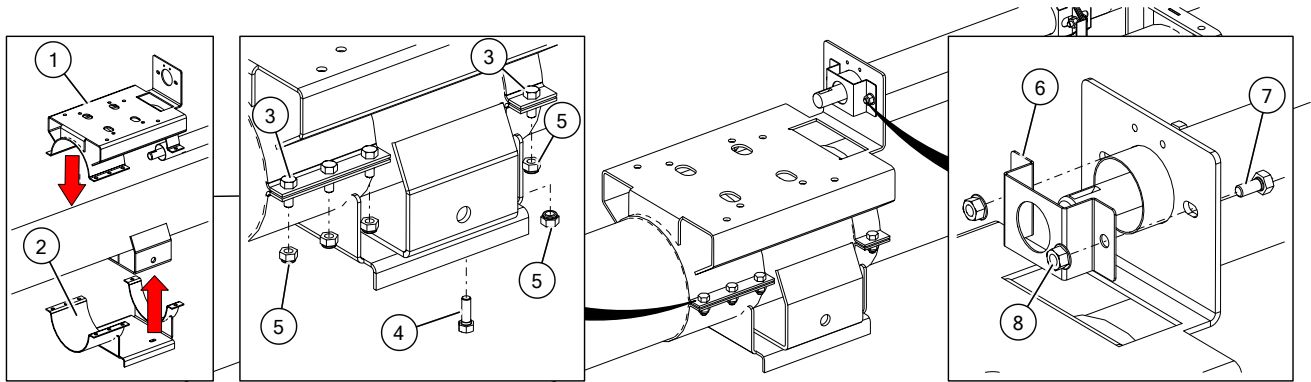

1	Clamp-On BD Gearbox Mount	5	Locknut, 7/16"
2	Bottom BD Half Clamp Mount	6	Driveshaft Guard Hanger Bracket
3	Bolt, 7/16" x 1"	7	Bolt, 3/8" x 1"
4	Bolt, 7/16" x 1-1/4"	8	Whiznut, 3/8"

46'/51' Models Only

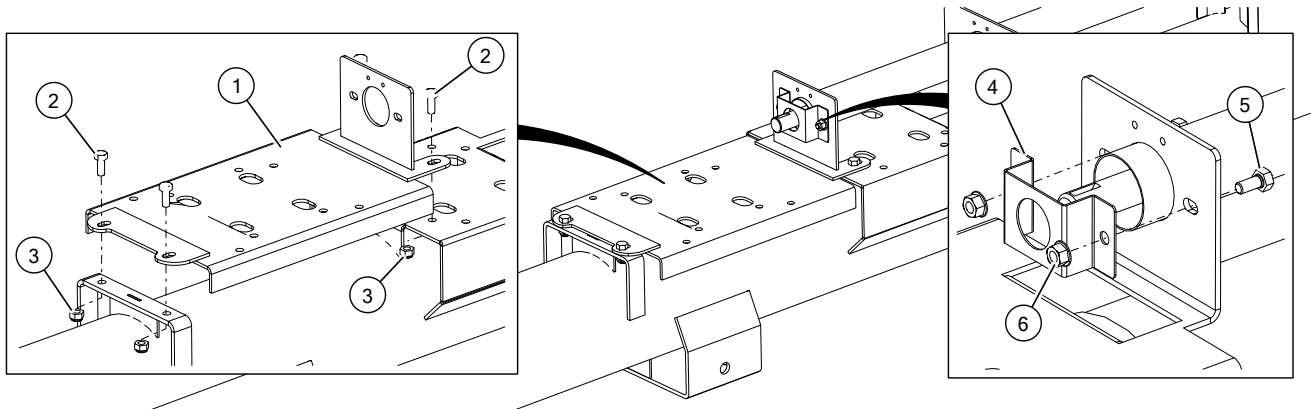

1	BD Gearbox Mount	4	Driveshaft Guard Hanger Bracket
2	Bolt, 7/16" x 1"	5	Bolt, 3/8" x 1"
3	Locknut, 7/16"	6	Whiznut, 3/8"

Installing the Gearbox

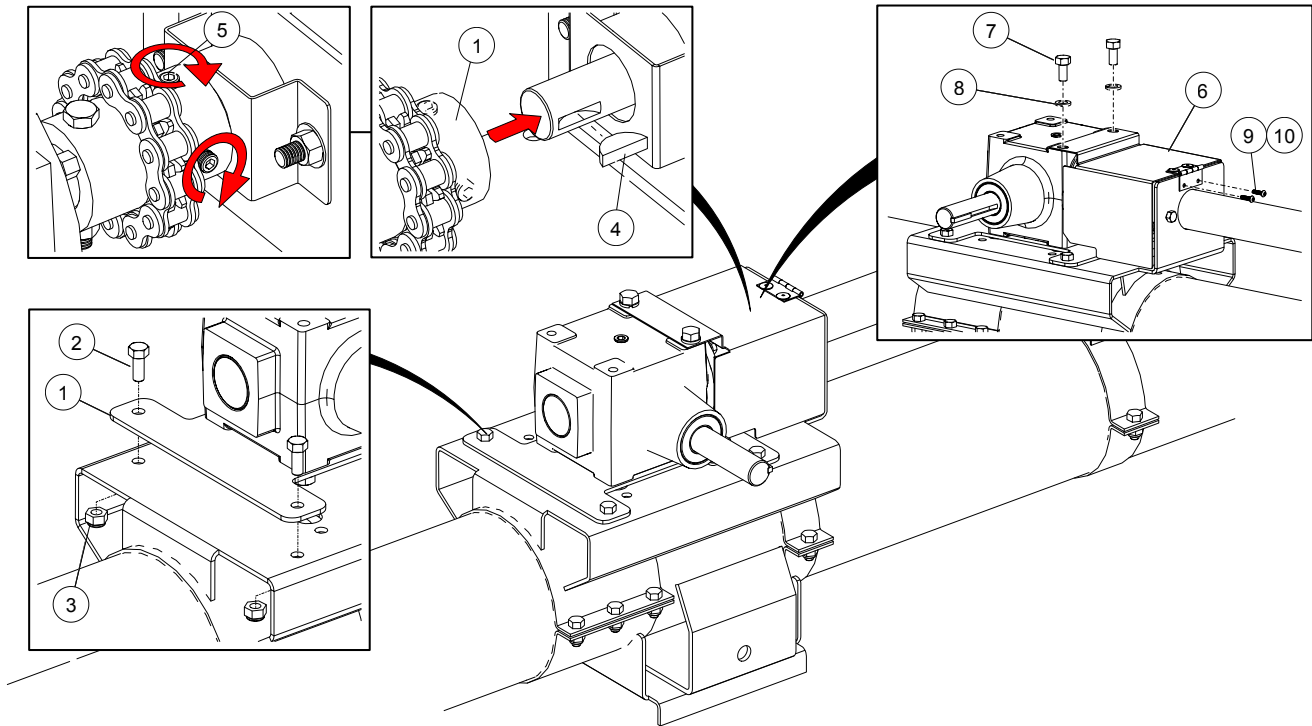

Assembly Notes:

- Check the gearbox oil level; gearbox should be half full. Use only EP90 lube oil and fill to HALF FULL only.
- The ends of the gearbox shaft and the driveshaft should be flush with the inside of the chain coupler sprockets.

If the driveshaft is too long or too short, do the following:

- If the driveshaft is too long, take up the extra length in the driveshaft connector(s).

Note

There may be more than one driveshaft connector in the drive system.

- If the driveshaft is too short, remove the headcover, chain, sprocket, and lock collar at the top of the upper tube to adjust the two driveshafts.

1	Clamp-On Gearbox Assembly	6	Locknut, 7/16"
2	Half Clamp	7	Bolt, 1/2" x 1"
3	Woodruff Key, 1/4" x 1"	8	Lock Washer, 1/2"
4	Set Screw, 3/8" x 3/8"	9	Bolt, #10 x 3/4"
5	Bolt, 7/16" x 1"	10	Locknut, #10

Installing the Gearbox Brackets

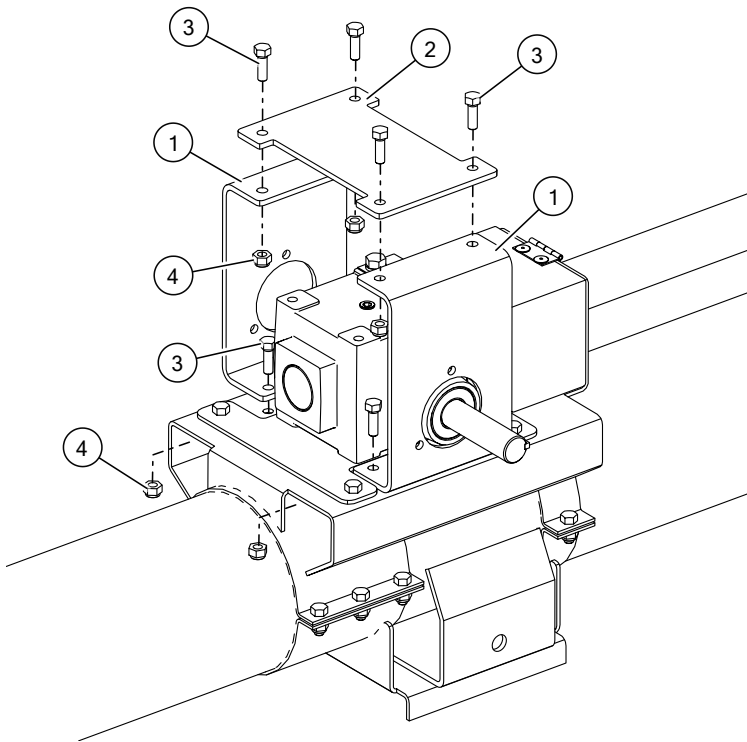

1	Connect Bracket
2	Top Cover Bracket
3	Bolt, 7/16" x 1-1/4"
4	Locknut, 7/16"

4.17. Assemble the Frame

4.17.1 Installing Upper and Lower Frame Arms

31'/36'/41' Models

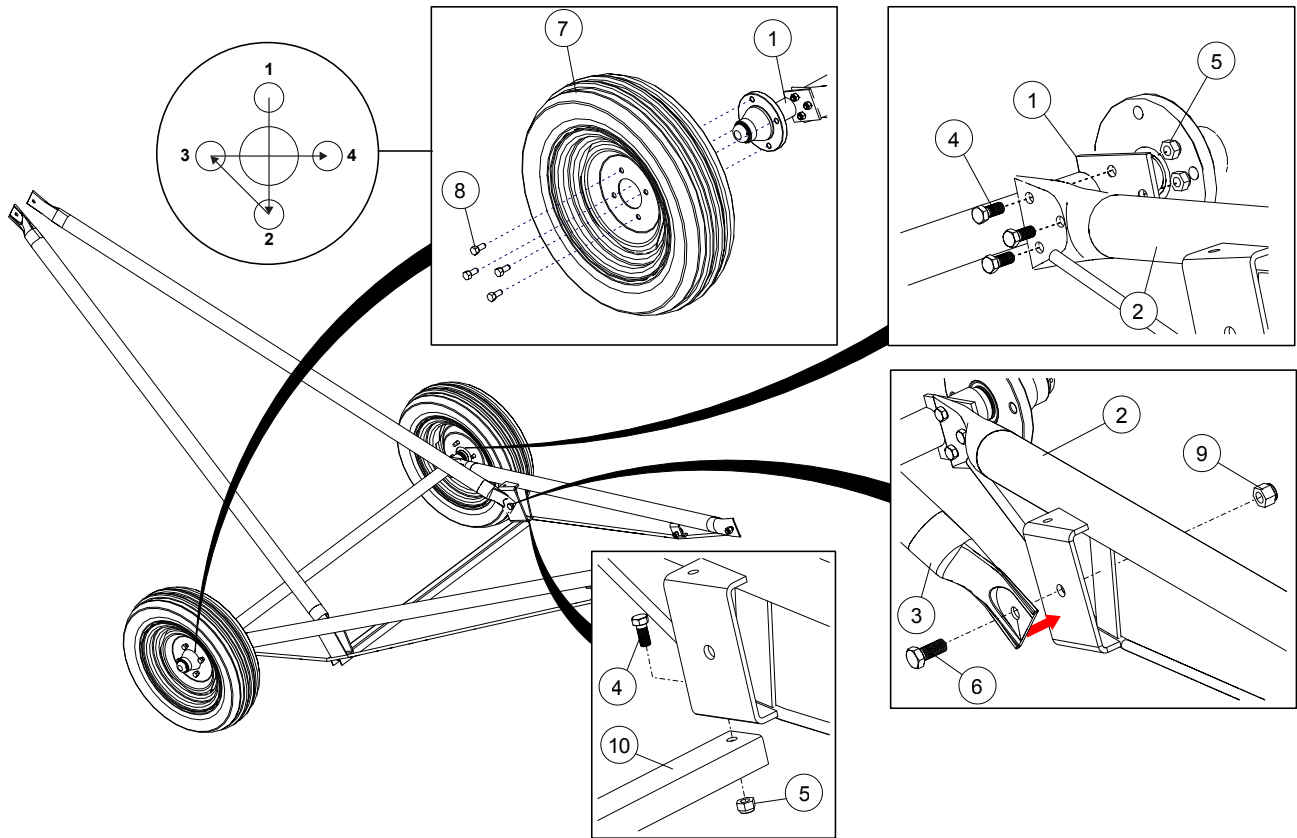

Assembly Notes:

- Put axle up on stands for easier assembly.
- Check that air pressure in the tires match pressure indicated on the tire sidewall.
- Torque the wheel bolts to 80 ft·lb ± 10 ft·lb (108.5 N·m ± 13.5 N·m) using the pattern shown.

1	Axle	6	Bolt, 5/8" x 1-1/2"
2	Lower Frame Arm	7	Wheel
3	Upper Frame Arm	8	Wheel Bolt, 1/2" x 1"
4	Bolt, 7/16" x 1"	9	Locknut, 5/8"
5	Locknut, 7/16"	10	Long Crossmember

46'/51'/56'/61'/71'/76' Models

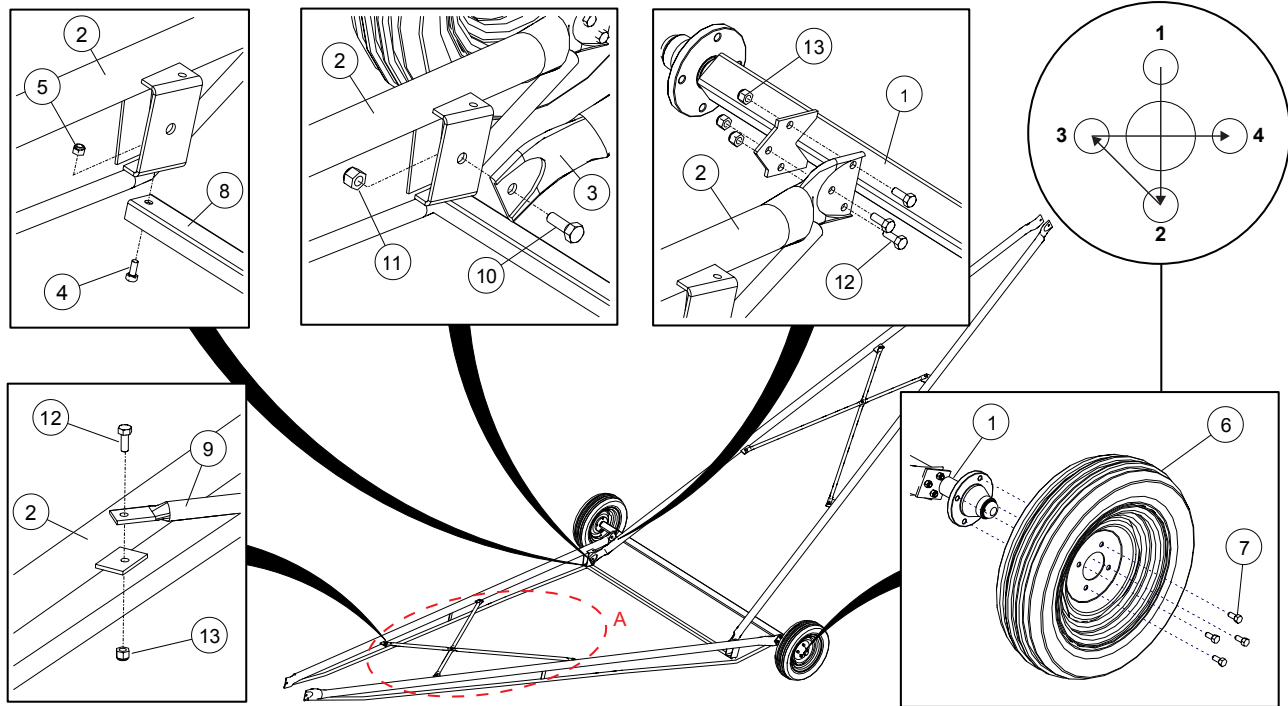

Assembly Notes:

- **46'/51' BD Models Only:** Do not install lower arm cross braces (A).
- Put axle up on stands for easier assembly.
- Check that air pressure in the tires match pressure indicated on the tire sidewall.
- Torque the wheel bolts to 80 ft·lb ± 10 ft·lb (108.5 N·m ± 13.5 N·m) using the pattern shown.

1	Axle	8	Long Crossmember
2	Lower Frame Arm	9	Cross Brace
3	Upper Frame Arm	10	Bolt, 3/4" x 2"
4	Bolt, 7/16" x 1"	11	Locknut, 3/4"
5	Locknut, 7/16"	12	Bolt, 1/2" x 1-1/4"
6	Wheel	13	Locknut, 1/2"
7	Wheel Bolt, 1/2" x 1"		

4.17.2 Install the Frame Extensions

For PTO-BD Models Only

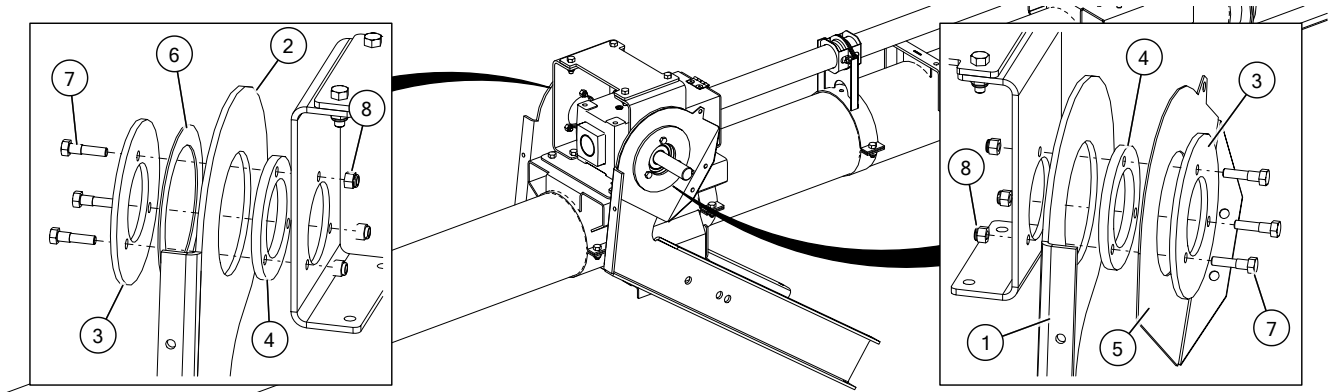

Assembly Notes:

- Do not overtighten the motor mount arms to the gearbox pivots.
- Ensure that the guard back plate is centered on the bolt plates.

1	BD Frame Extension, RH	5	Guard Back Plate
2	BD Frame Extension, LH	6	Spacer
3	Bolt Plate, Large	7	Bolt, 3/8" x 1-1/2"
4	Bolt Plate, Small	8	Locknut, 3/8"

4.18. Attach Frame to Tube

Important

Be sure to use proper hoisting equipment and procedures when raising the discharge end of the auger. Lock out the hoist apparatus prior to working around or under the raised tube.

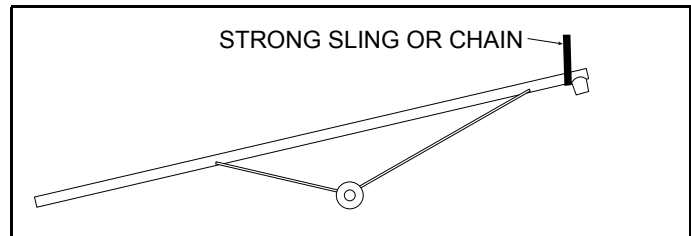

4.18.1 Attach Upper and Lower Frame Arms

EMD, MD, PTO-SD, and Hydraulic Drive Options Only

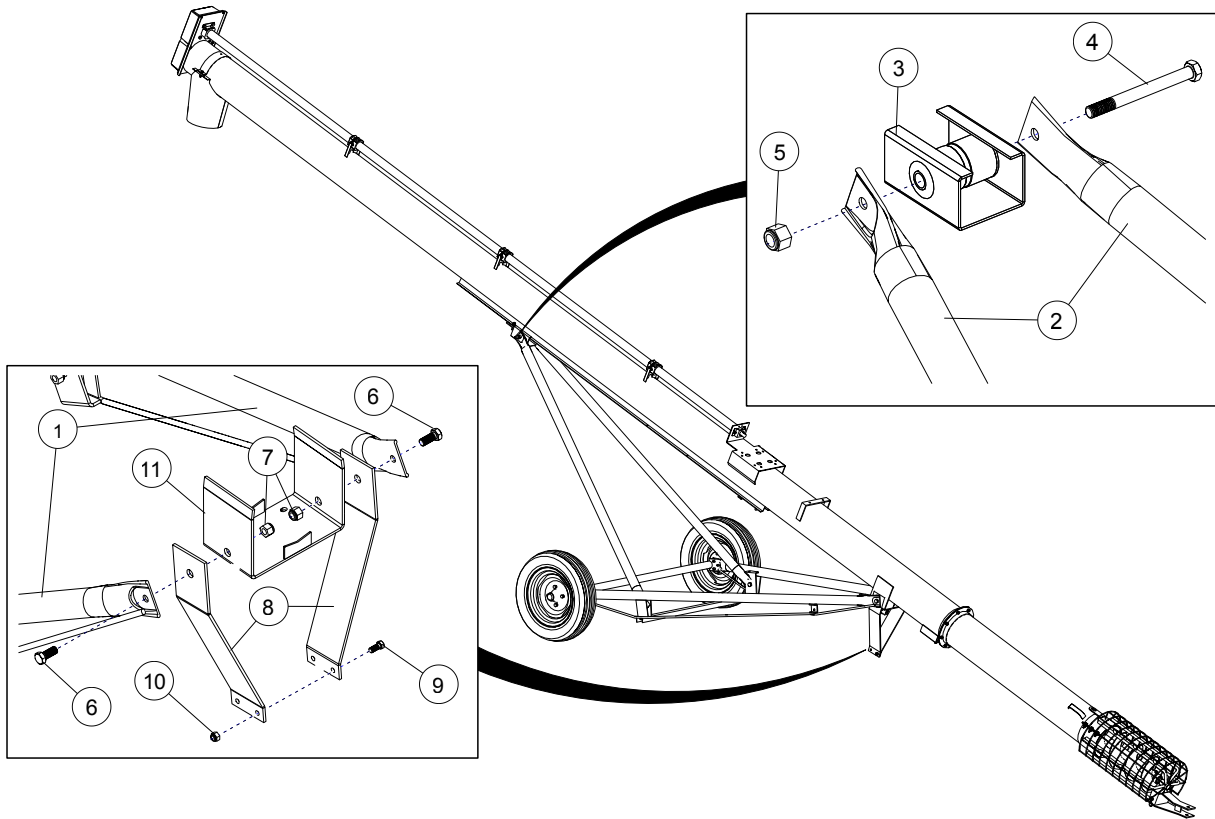

Assembly Note:

- Remove the stand from the intake end of the auger tube and raise the discharge end with a block and tackle or a front end loader and a strong sling or chain. Height should be sufficient so the frame can be positioned under the tube and the lift arms can be easily attached to the track shoe.

1	Lower Frame Arm	6	Bolt, 3/4" x 2"
2	Upper Frame Arm	7	Locknut, 3/4"
3	Track Shoe (Installed in a previous section)	8	Stabilizer Bracket
4A	Bolt, 5/8" x 6-1/2" (31'-41' Models)	9	Bolt, 7/16" x 1"
4B	Bolt, 3/4" x 6-1/2" (46'-76' Models)	10	Locknut, 7/16"
5A	Locknut, 5/8" (31'-41' Models)	11	Tube Bracket (pre-welded to the tube)
5B	Locknut, 3/4" (46'-76' Models)		

For Augers with the PTO-BD Drive Option Only

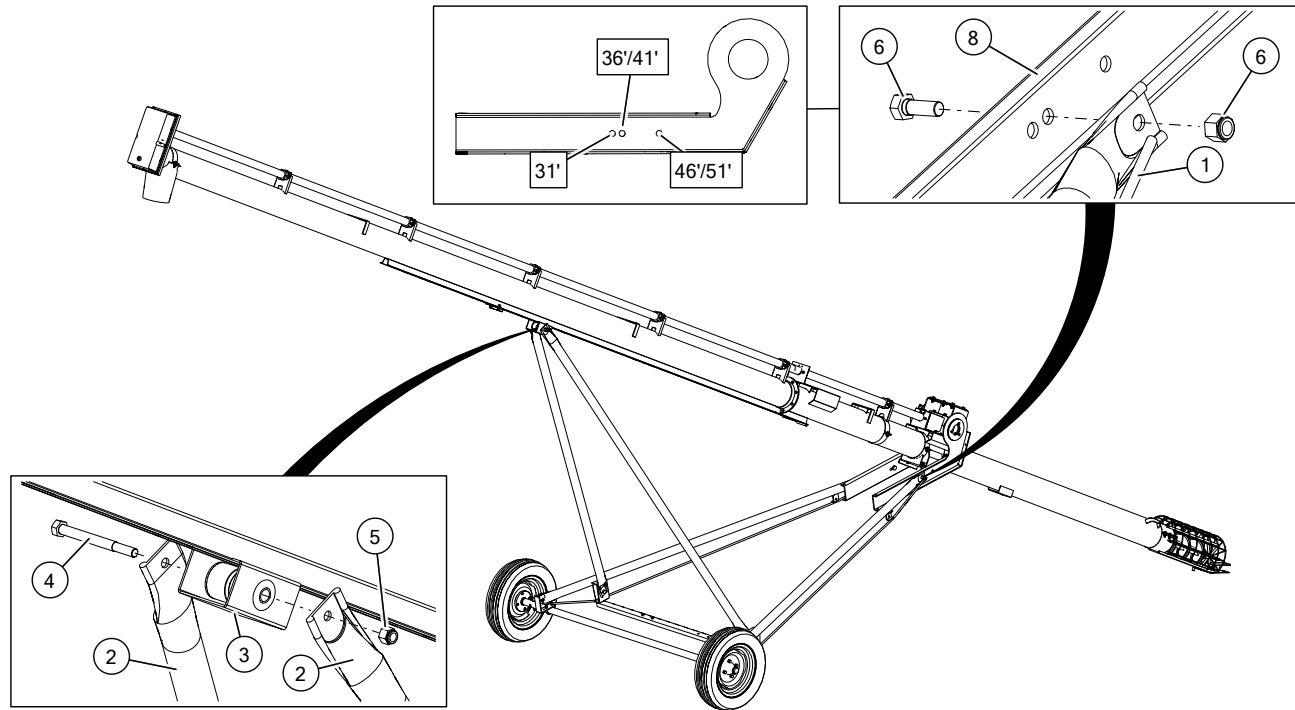

Assembly Notes:

- Remove the stand from the intake end of the auger tube and raise the discharge end with a block and tackle or a front end loader and a strong sling or chain. Height should be sufficient so the frame can be positioned under the tube and the lift arms can be easily attached to the track shoe.
- Ensure lower frames are attached to the frame extensions with the bolts facing outward.

1	Lower Frame Arm	5	Locknut, 5/8" (31' – 41' Models)
2	Upper Frame Arm		Locknut, 3/4" (46'/51' Models)
3	Track Shoe (Installed in previous section)	6	Bolt, 3/4" x 2"
4	Bolt, 5/8" x 6-1/2" (31' – 41' Models)	7	Locknut, 3/4"
	Bolt, 3/4" x 6-1/2" (46'/51' Models)	8	Frame Extension Brackets

4.18.2 Attach Stabilizer Pieces

EMD, MD, PTO-SD, and Hydraulic Drive Options Only

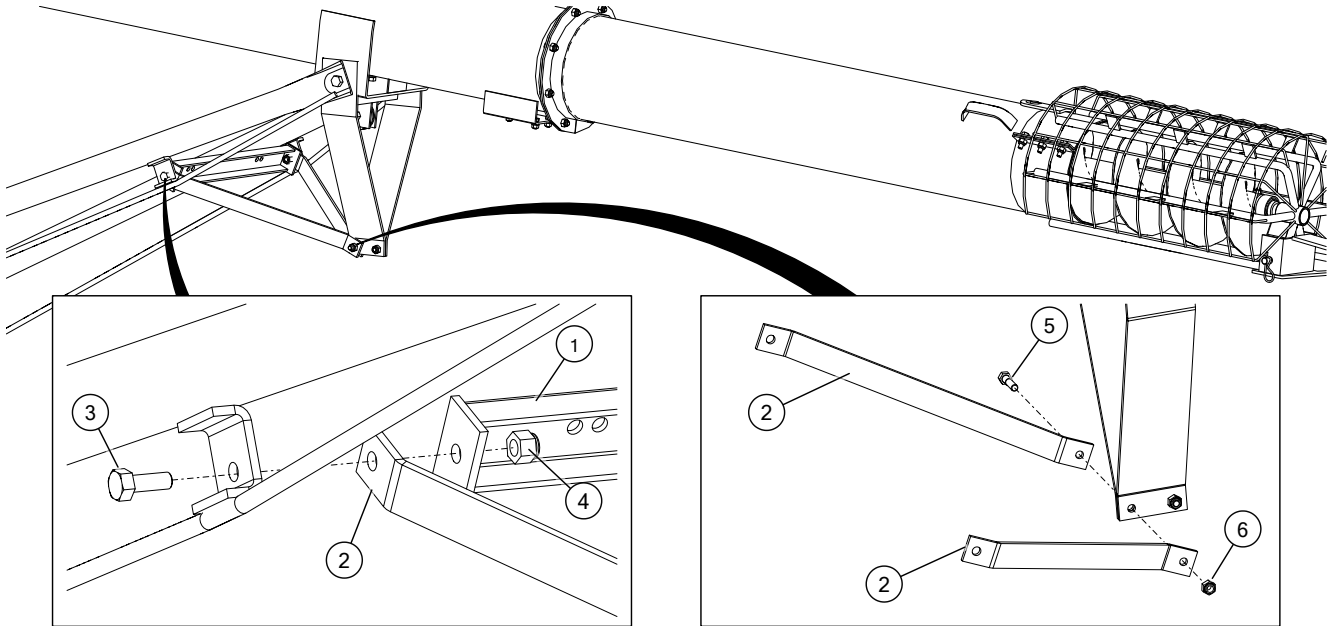

1	Short Crossmember	4	Locknut, 1/2"
2	Stabilizer Brace	5	Bolt, 7/16" x 1-3/4"
3	Bolt, 1/2" x 1-1/2"	6	Locknut, 7/16"

PTO-BD Drive Option Only

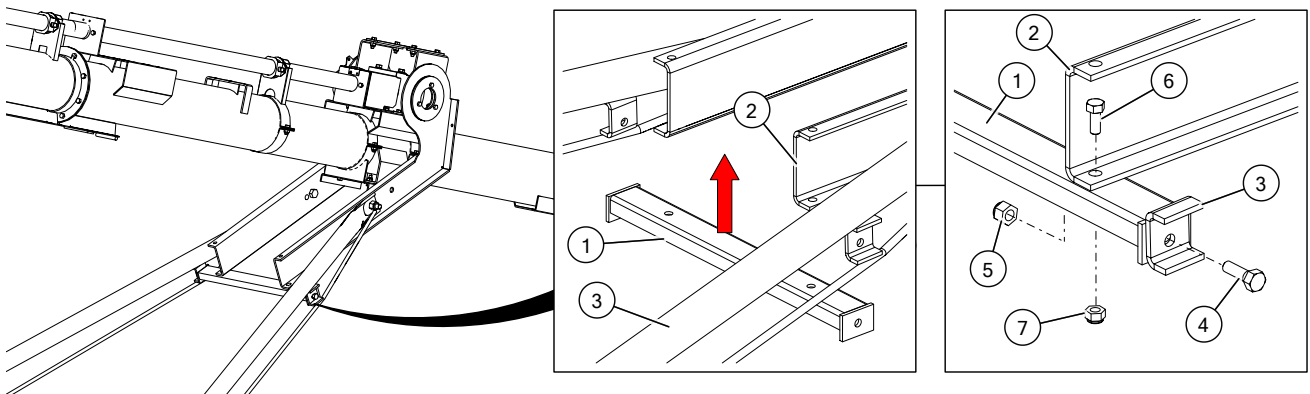

1	Short Crossmember	5	Locknut, 1/2"
2	Frame Extensions	6	Bolt, 7/16" x 1"
3	Lower Frame Arm	7	Locknut, 7/16"
4	Bolt, 1/2" x 1-1/2"		

4.19. Install the Manual Winch and Connect the Lift Cable

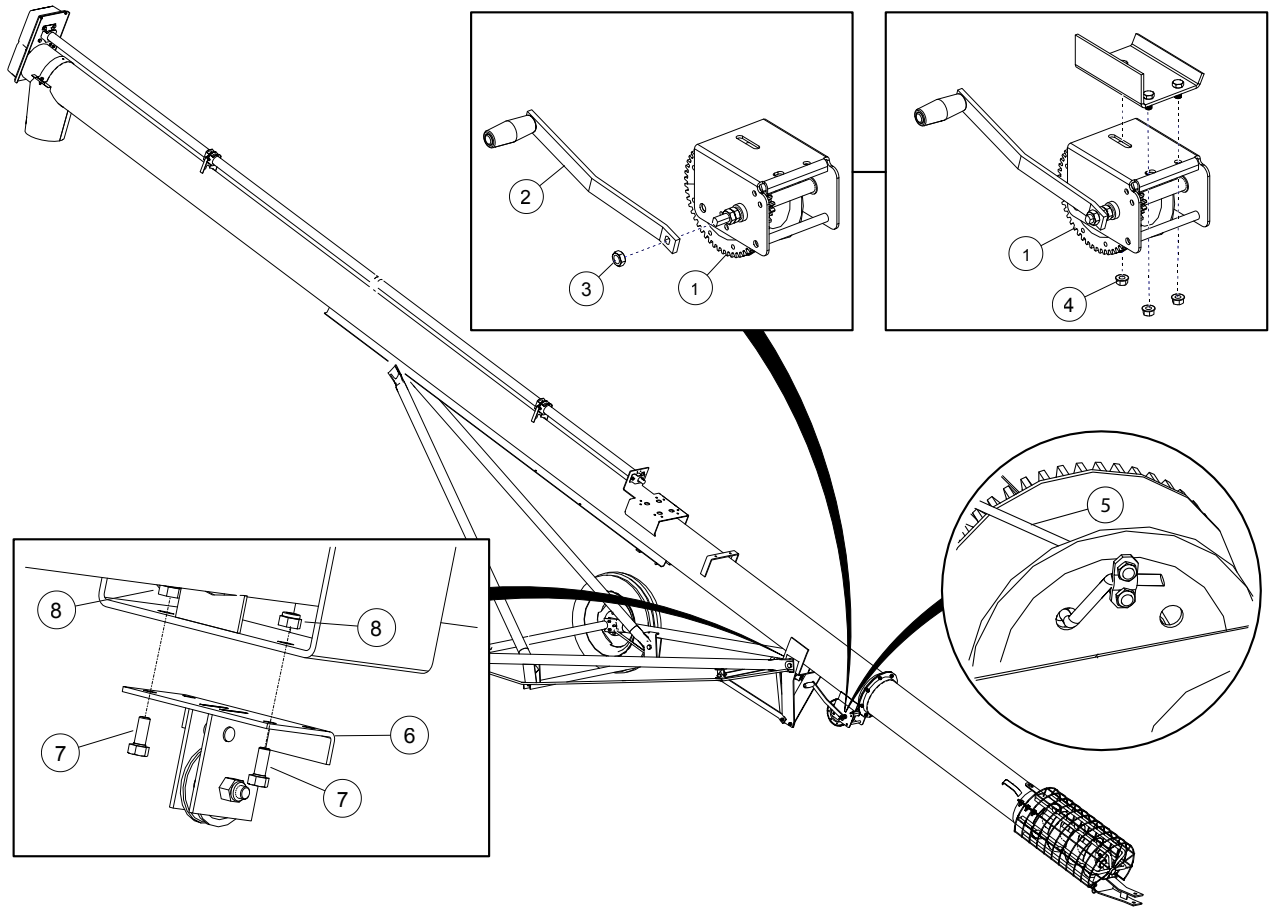

Assembly Notes:

- Do not remove or loosen the double locknut on the winch input shaft; it is an important part of the winch brake system.
- The cable guide assembly is only required for augers with the motor drive (MD).

1	Manual Winch	5	Winch Cable
2	Winch Handle	6	Cable Guide Assembly
3	Locknut, 1/2"	7	Bolt, 7/16" x 1"
4	Whiznut, 3/8"	8	Locknut, 7/16"

1. Pull cable to the winch.
MD Only: Run cable through the cable guide.
2. Wrap the cable over and around the winch drum.
3. Thread the cable through the hole in the side of the winch drum and secure it using a cable clamp.

Important

Make sure there is a minimum of three wraps of cable on the winch drum when the auger is in transport position.

4.20. Install the Electric Motor Drive

4.20.1 Install the EMD Mount Assembly

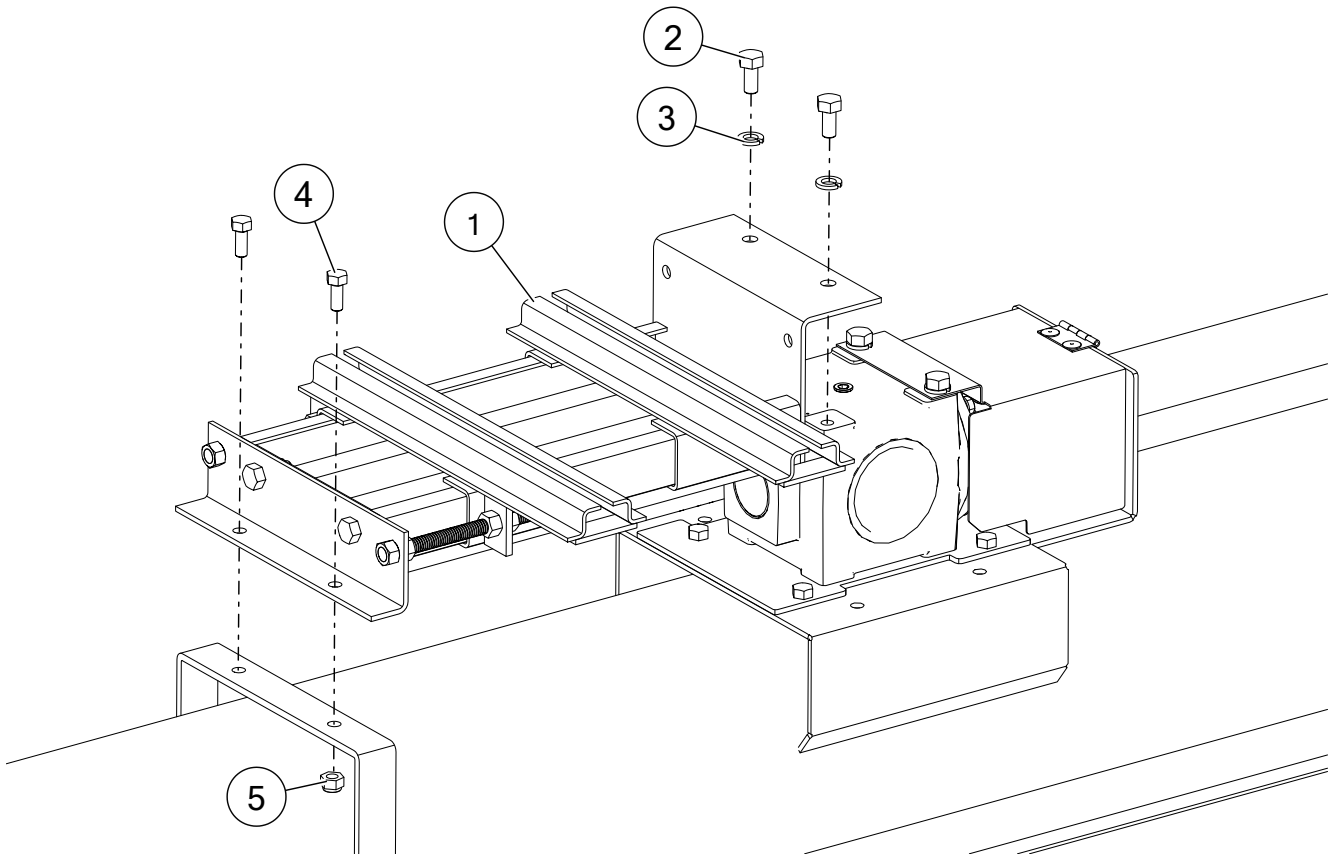

1	EMD Mount Assembly	4	Bolt, 7/16" x 1"
2	Bolt, 1/2" x 1"	5	Locknut, 7/16"
3	Lock Washer, 1/2"		

4.20.2 Install the Backplate Mount

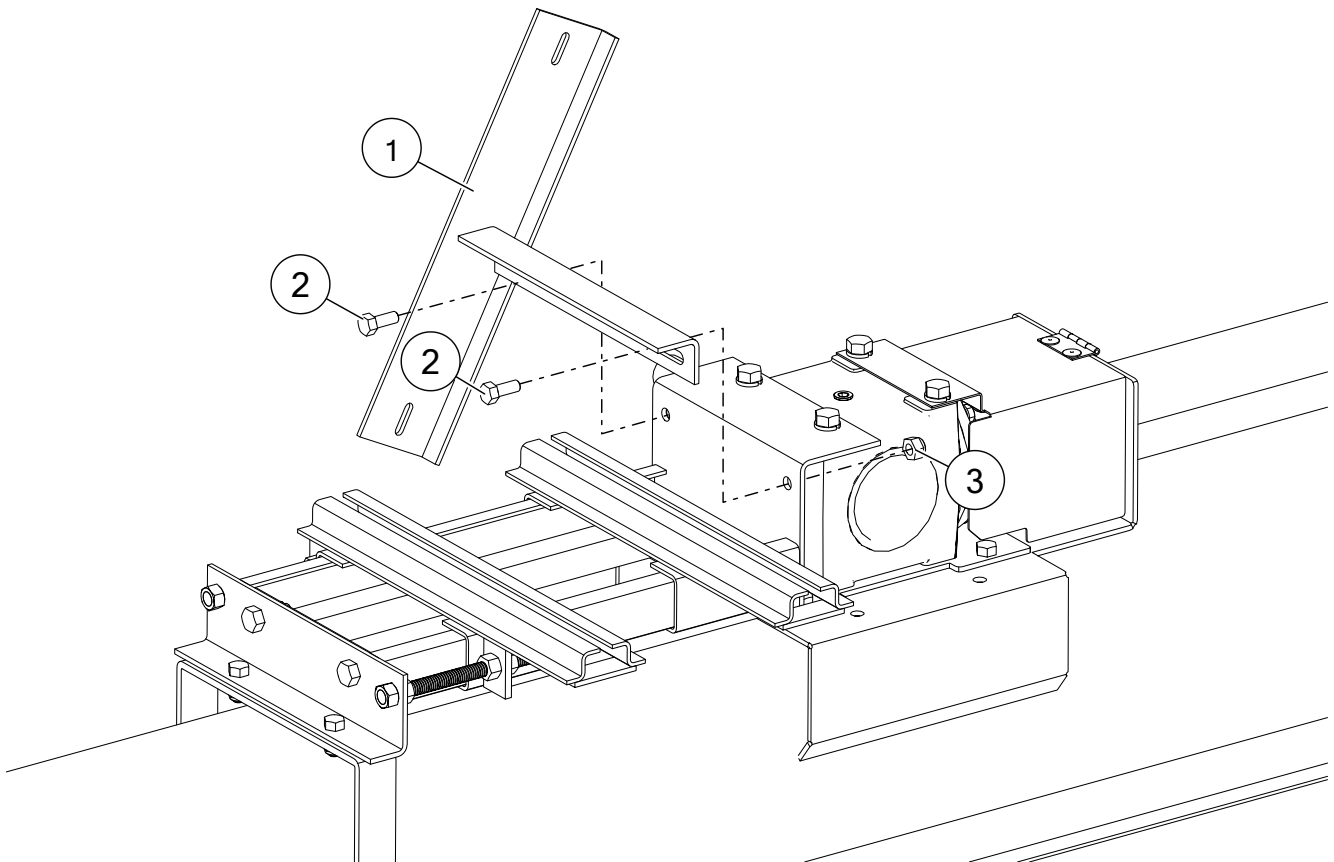

1	Back Plate Mount	3	Locknut, 7/16"
2	Bolt, 7/16" x 1"		

4.20.3 Install the Electric Motor

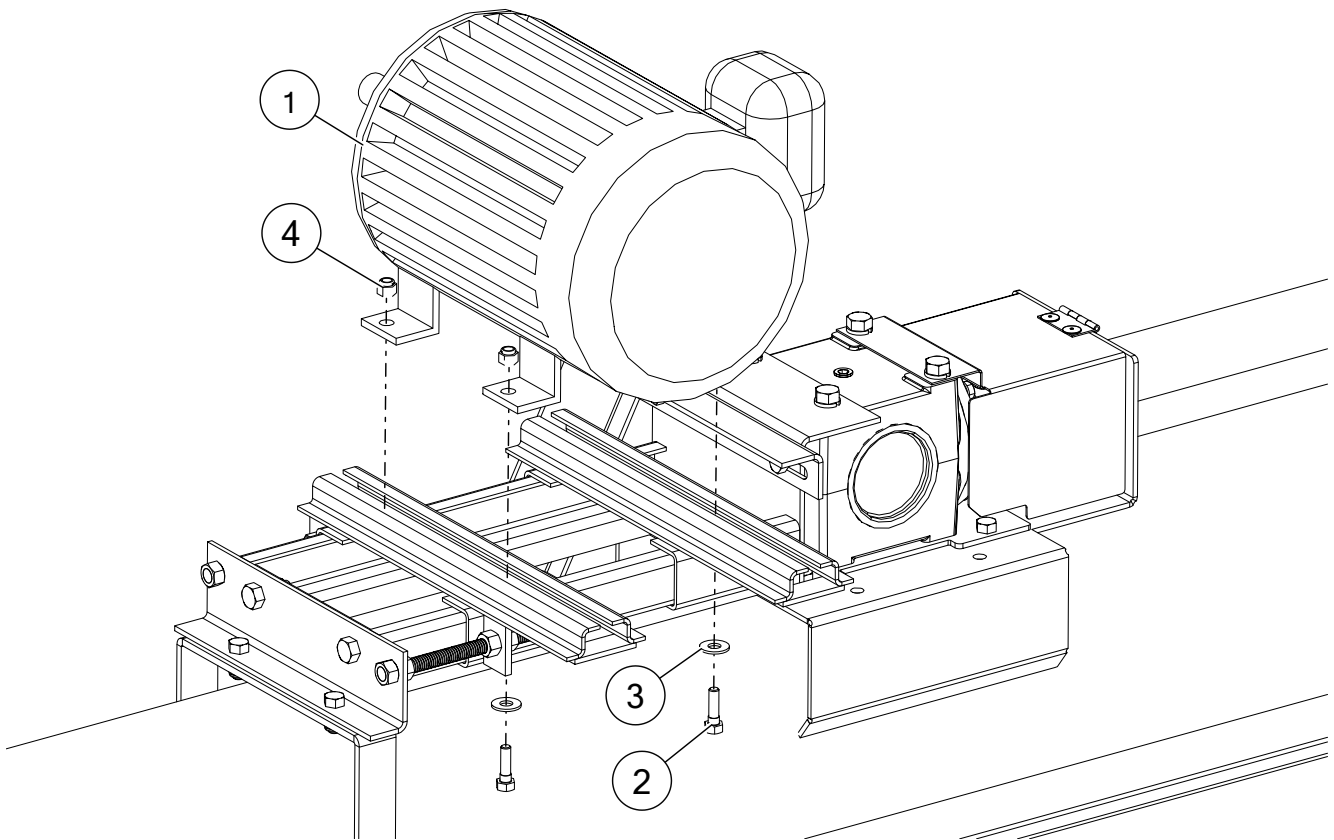

1	Electric Motor	3	Flat Washer, 3/8"
2	Bolt, 3/8" x 1-1/4"	4	Locknut, 3/8"

4.20.4 Install the EMD Belt Guard Assembly

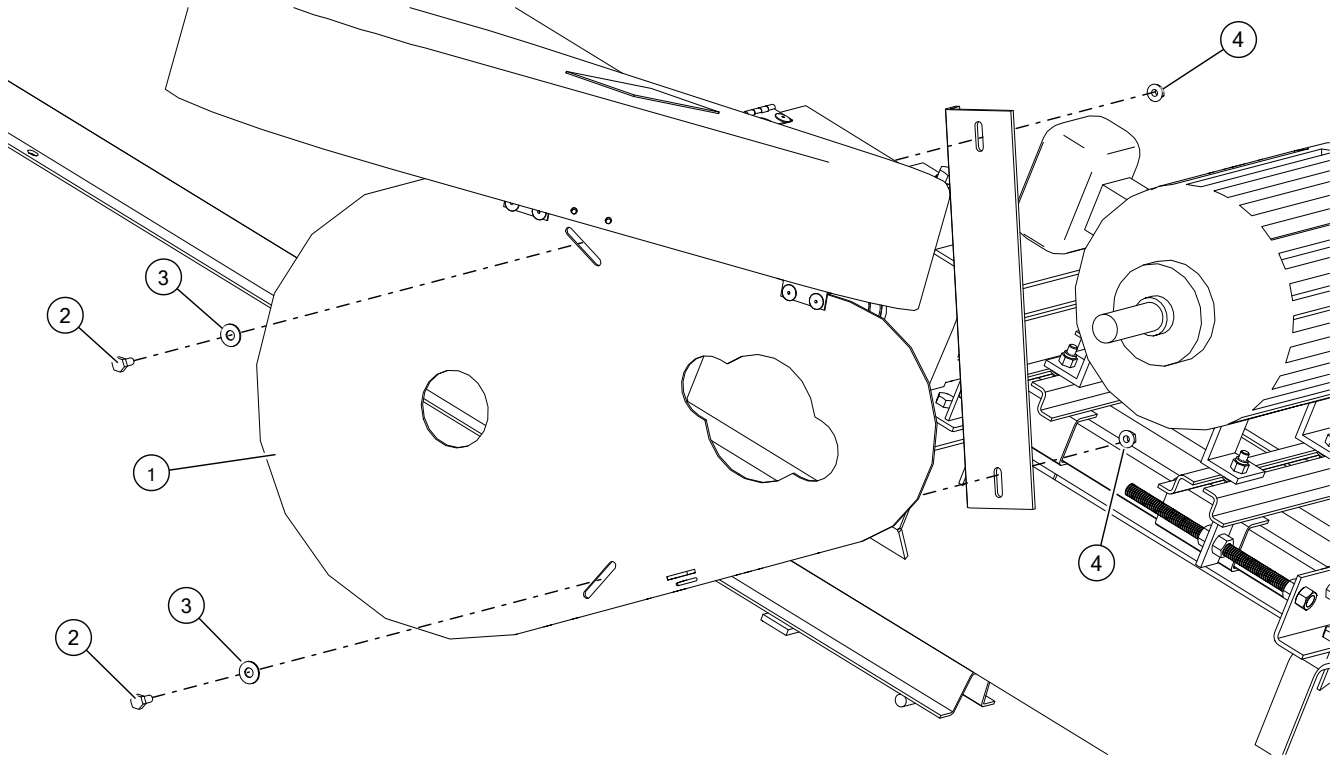

1	EMD Belt Guard Assembly	3	Flat Washer, 5/16"
2	Bolt, 5/16" x 3/4"	4	Flange Nut, 5/16"

4.20.5 Install the Pulleys

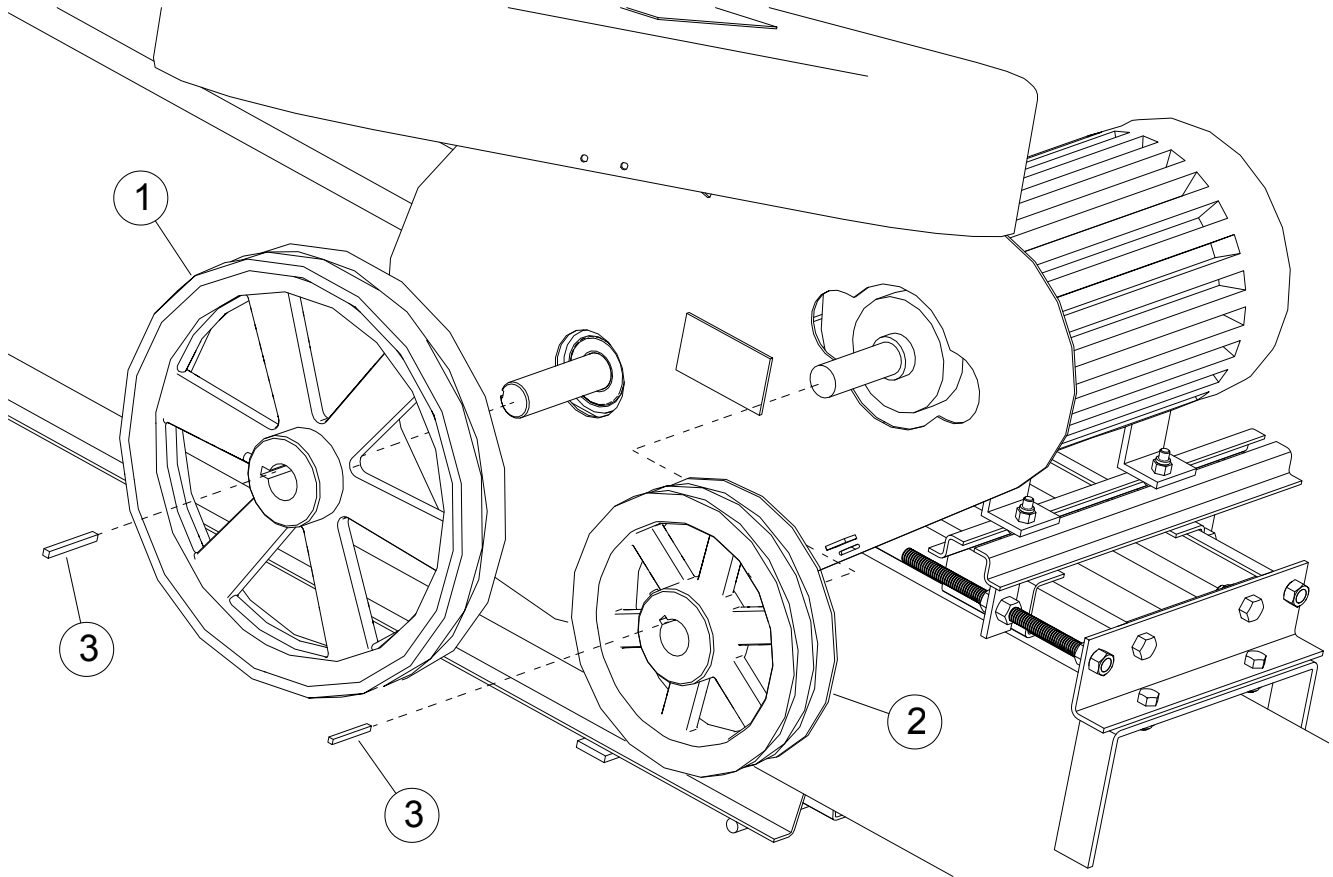

Assembly Notes:

- **31'–41' Models:** Use double pulleys.
- **46'–76' Models:** Use triple pulleys.
- Use a straight edge to align the pulleys.

1	Gearbox Pulley (supplied)	3	Square Key
2	Engine Pulley (7-3/4" OD recommended)		

4.20.6 Install the Belt

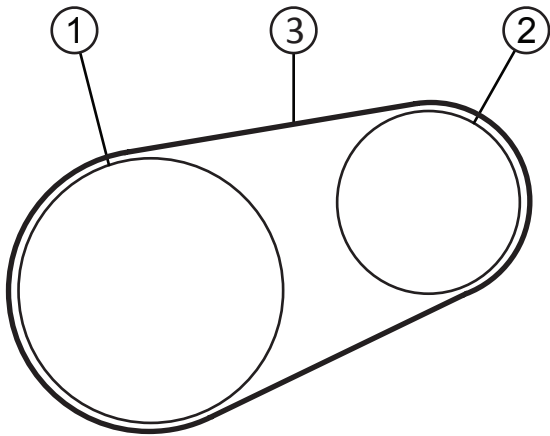

Assembly Note:

- The belt must run straight. Check the alignment of the pulleys and adjust if necessary.

1	Gearbox Pulley
2	Engine Pulley
3	Belt

4.20.7 Tension the Belt

Tensioning the Belt

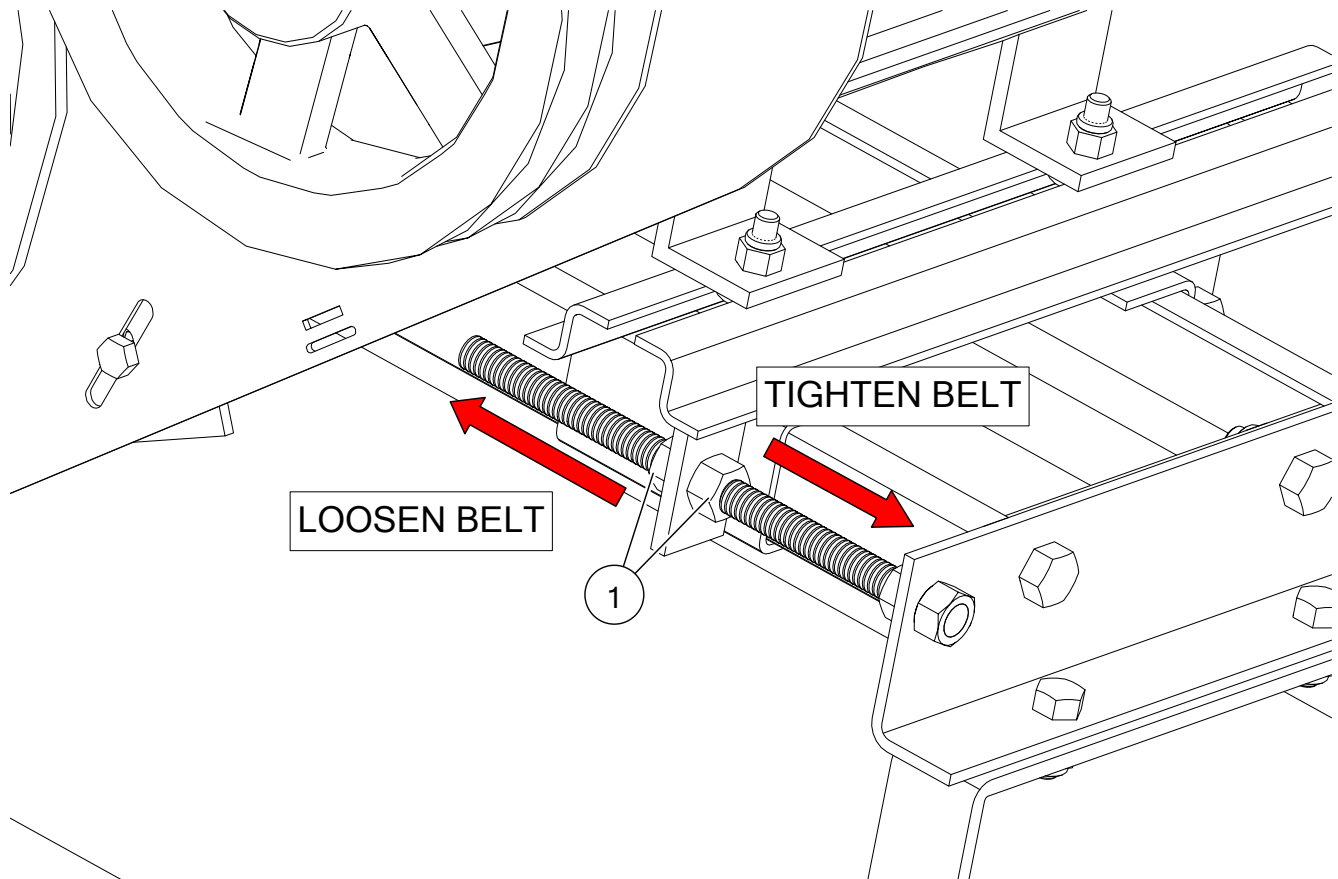

Assembly Note:

- Use the two hex nuts to apply tension to the drive belt.
- Once satisfied with belt tension, lock the two nuts against each other (turn in opposite directions).

1	Hex Nut, 1/2"
---	---------------

Locking the Guard

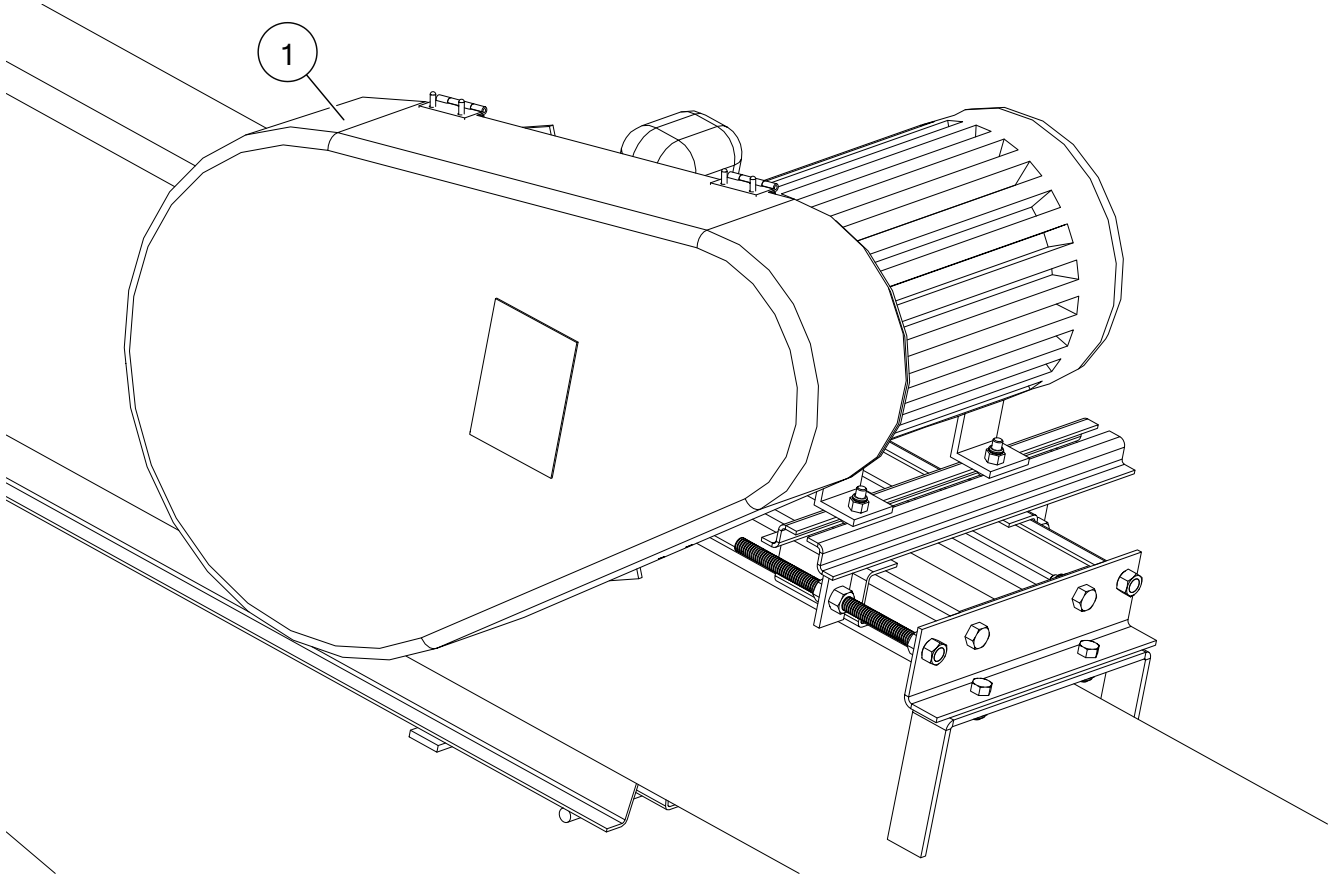

Assembly Note:

- Close and lock the belt guard into place.

1	EMD Belt Guard Assembly
---	-------------------------

4.21. Install the Motor Drive

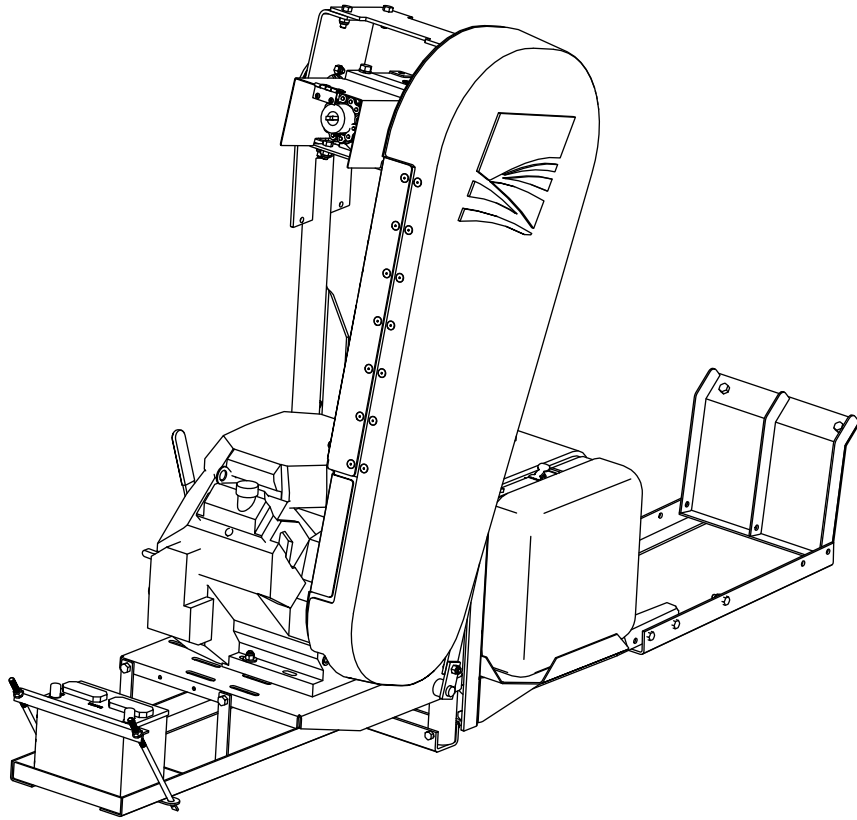

4.21.1 Install the Motor Mount

Installing Motor Mount Arms

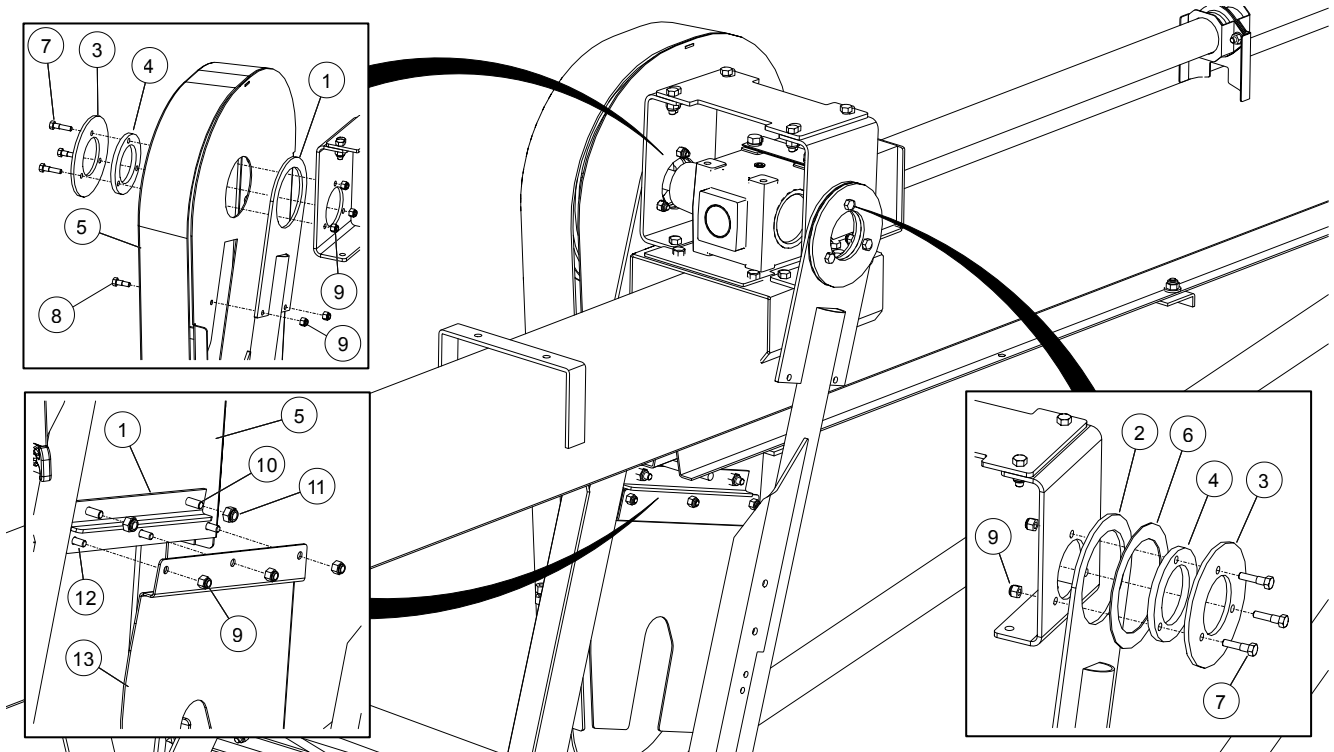

Assembly Notes:

- Do not overtighten the motor mount arms to the gearbox pivots.
- Ensure that the gearbox back plate is centered on the bolt plates.

1	Motor Mount Arm, LH	8	Bolt, 3/8" x 1"
2	Motor Mount Arm, RH	9	Locknut, 3/8"
3	Bolt Plate, Large	10	Bolt, 7/16" x 1"
4	Bolt Plate, Small	11	Locknut, 7/16"
5	Poly Belt Guard Assembly	12	Bolt, 3/8" x 3/4"
6	Spacer	13	Base Back Plate (Electric Motors Only)
7	Bolt, 3/8" x 1-1/2"		

Assembling Motor Mount

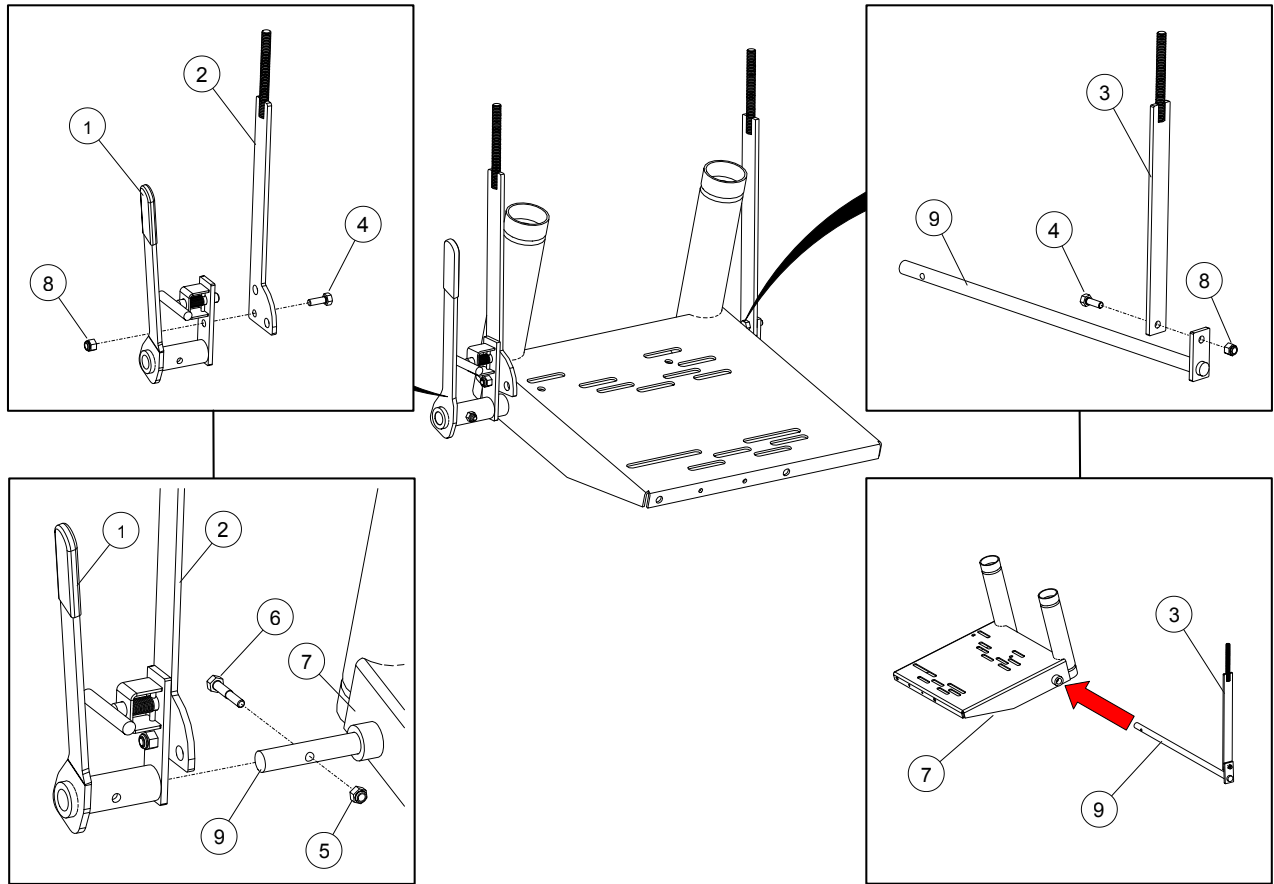

1	Belt Tensioner Handle Assembly	6	Bolt, 5/16" x 1-3/4"
2	Back Pivot Arm, RH	7	Motor Mount
3	Back Pivot Arm, LH	8	Locknut, 3/8"
4	Bolt, 3/8" x 1"	9	Pivot Rod
5	Locknut, 5/16"		

Installing Motor Mount

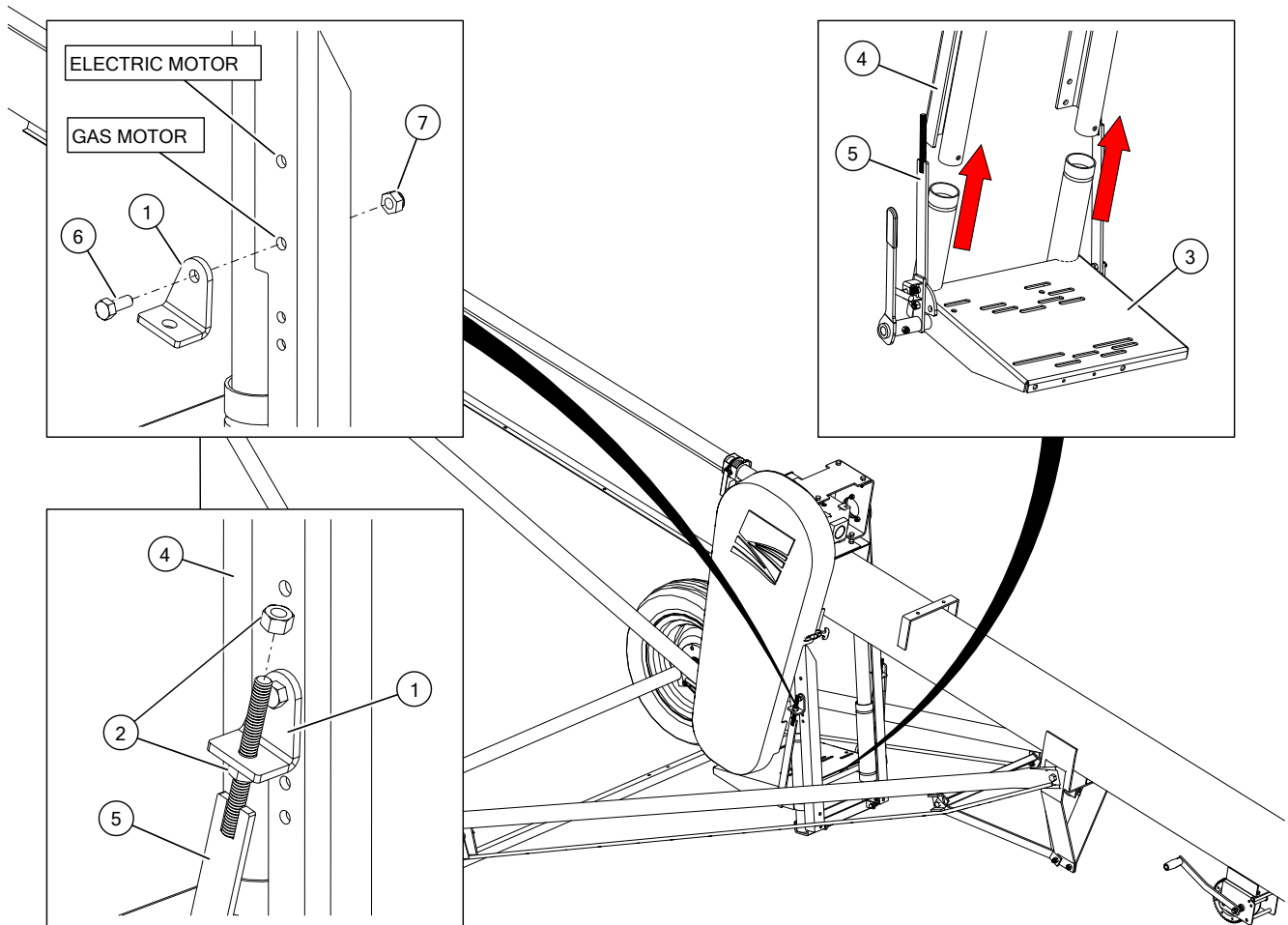

1	Pivot Arm Mount Bracket	5	Back Pivot Arm
2	Hex Nut, 1/2"	6	Bolt, 7/16" x 1"
3	Motor Mount	7	Locknut, 7/16"
4	Motor Mount Arm		

Installing Stabilizer Arms

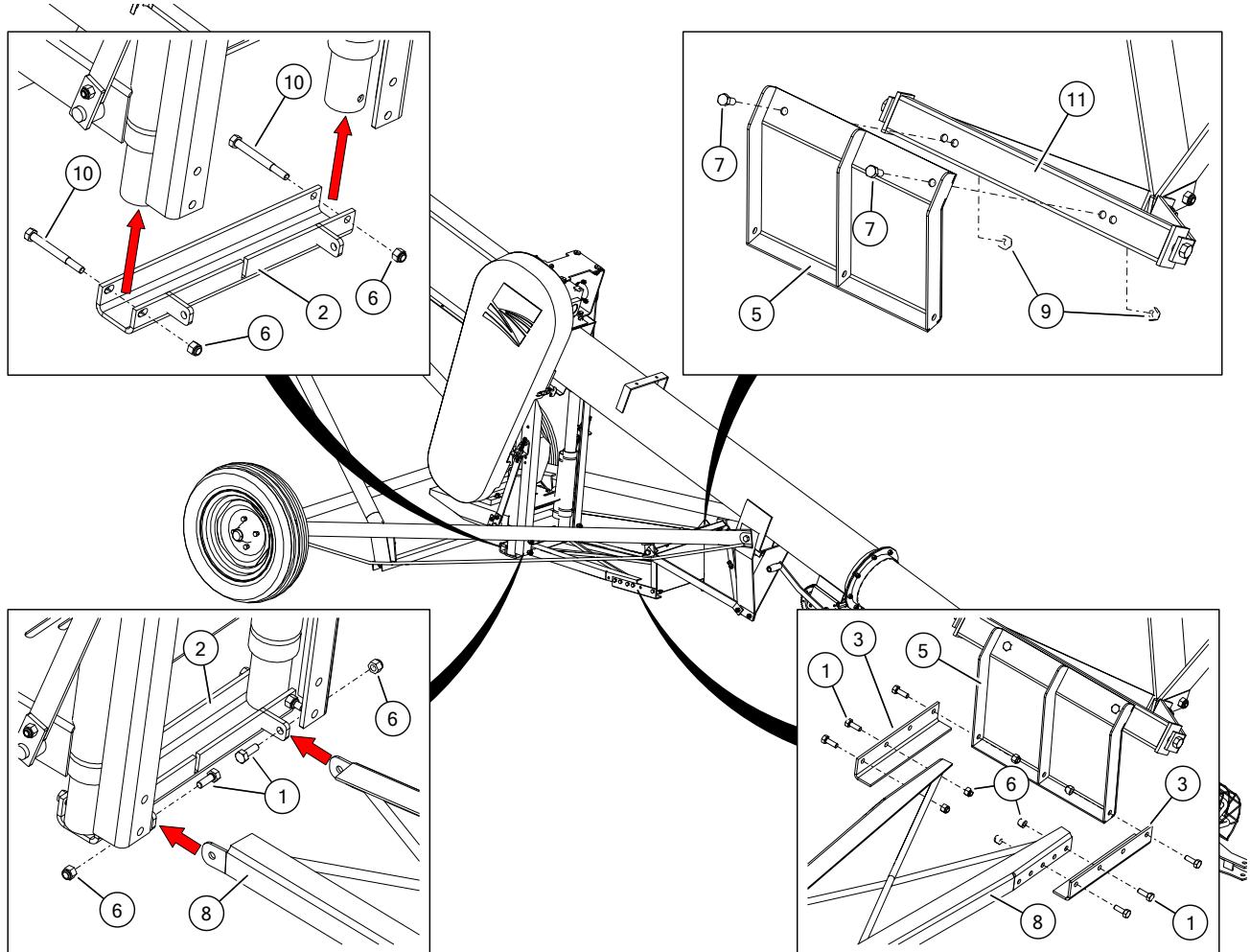

1	Bolt, 3/8" x 1"	7	Bolt, 7/16" x 1"
2	Stopper Plate	8	Stability Arm
3	Adjust Stabilizer Bracket, Short	9	Locknut, 7/16"
4	Motor Mount	10	Bolt, 3/8" x 3-1/2"
5	Stabilizing Arm Mount	11	Short Crossmember
6	Locknut, 3/8"		

4.21.2 Install the Battery and Fuel Tank (Gas Motor Only)

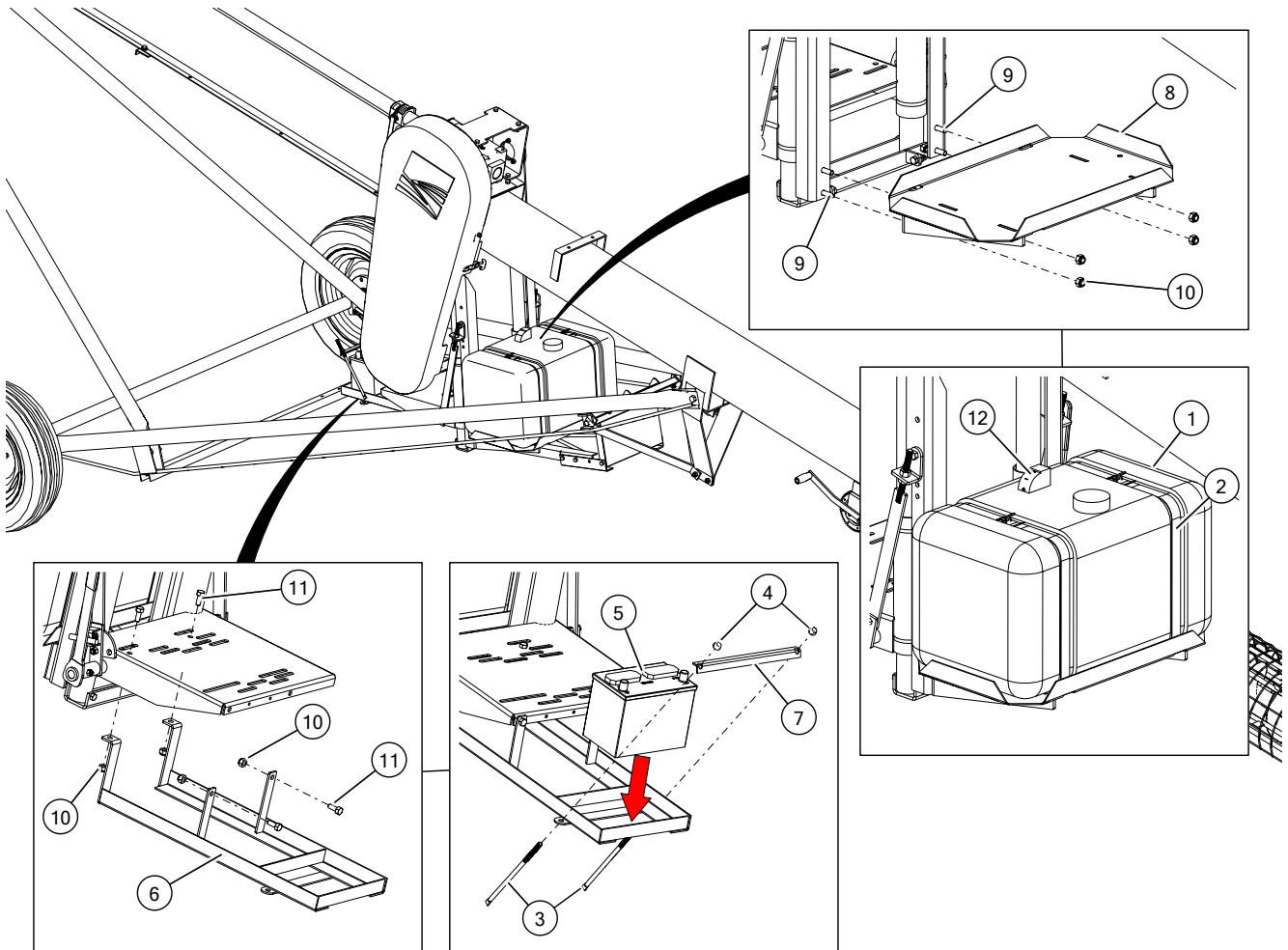

1	Fuel Tank	7	Battery Hold Down Strap
2	Fuel Tank Straps	8	Fuel Tank Mount
3	Battery Holder Bolts	9	Bolt, 7/16" x 1-1/4"
4	Whiznut, 3/8"	10	Locknut, 7/16"
5	Battery	11	Bolt, 7/16" x 1"
6	Battery Mount	12	Brass Fitting

4.21.3 Install the Motor

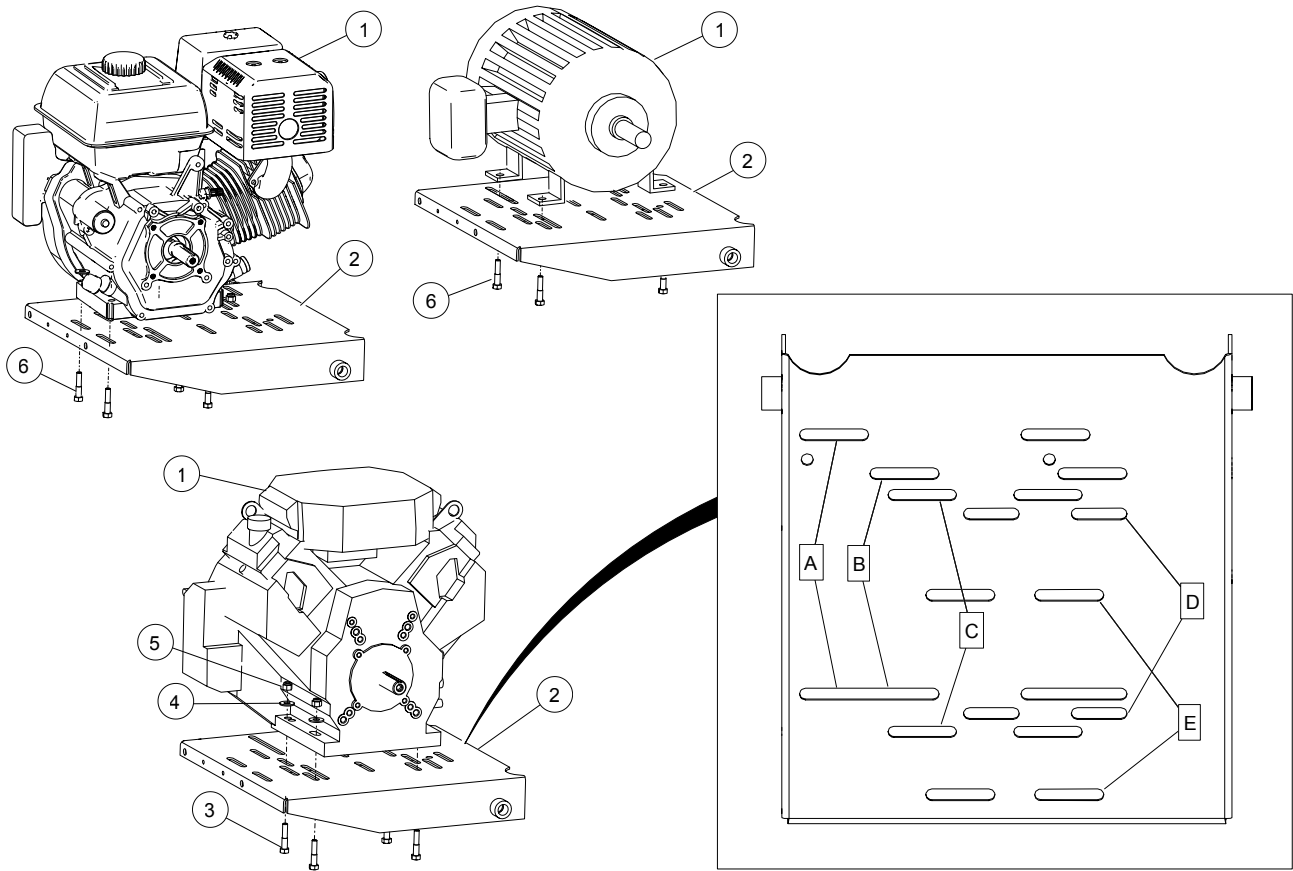

Assembly Notes:

- Install the exhaust pipe, muffler and muffler shield to the engine.
- Perform all the engine wiring.
- Run a fuel hose from the brass fitting to the fuel filter and secure with hose clamps.

1	Motor	A	Electric Motor, 15 HP — 20 HP
2	Motor Mount	B	Electric Motor, 7.5 HP — 10 HP
3	Bolt, 3/8" x 1-3/4"	C	Vanguard, 25 HP
4	Flat Washer, 3/8"	D	Honda, 20-22 HP
5	Locknut, 3/8"	E	Honda, 13 HP
6	Bolt (Not Supplied)		

4.21.4 Install the Engine Pulley

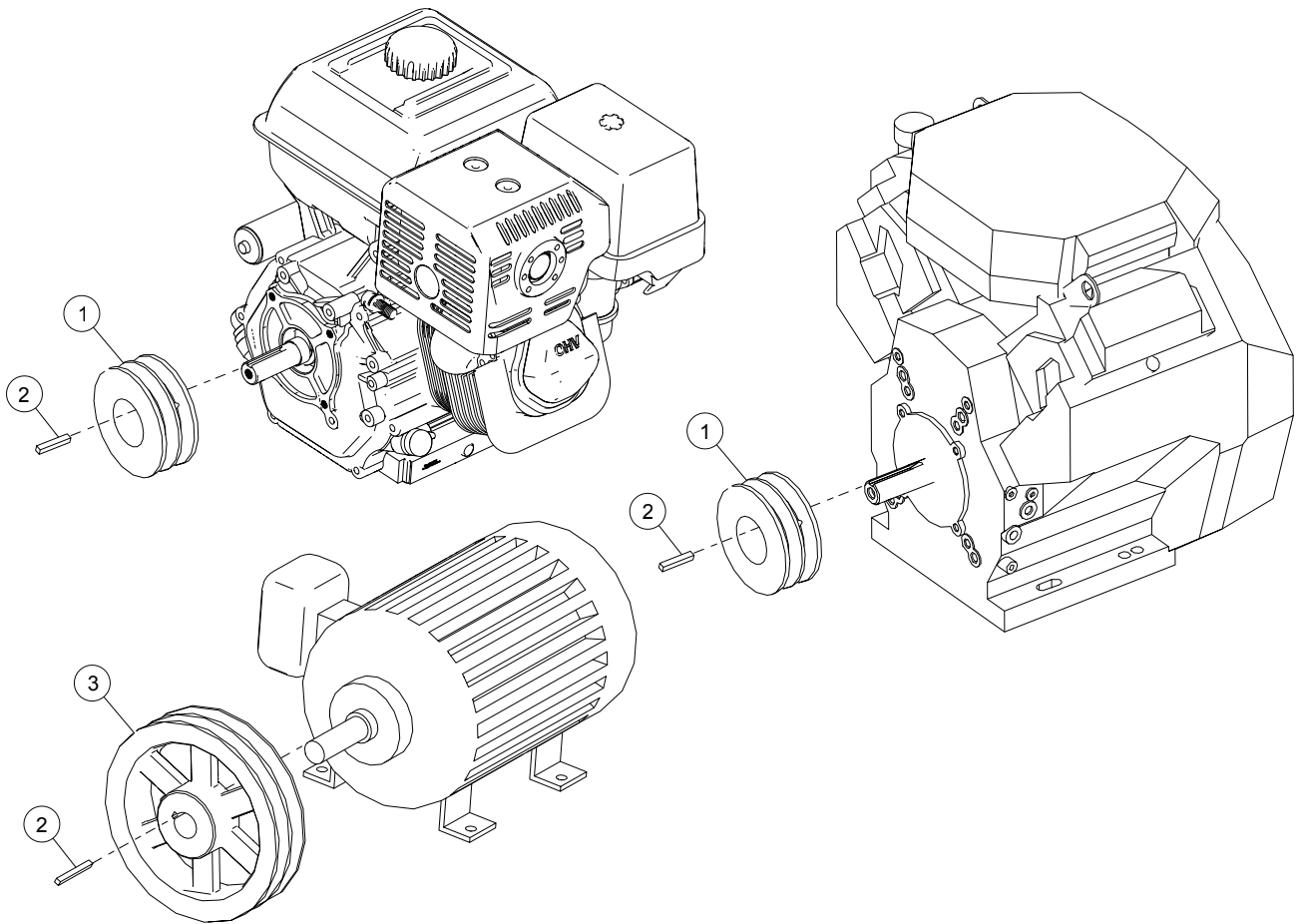

Assembly Note:			
<ul style="list-style-type: none"> The face of the motor shaft should be flush with the outside edge of the engine pulley. 			
1	Engine Pulley, Double (4-1/2" OD recommended)	3	Engine Pulley, Double (7-3/4" OD recommended)
2	Square Key, 1/4" x 1-1/2"		

4.21.5 Install the Gearbox Pulley

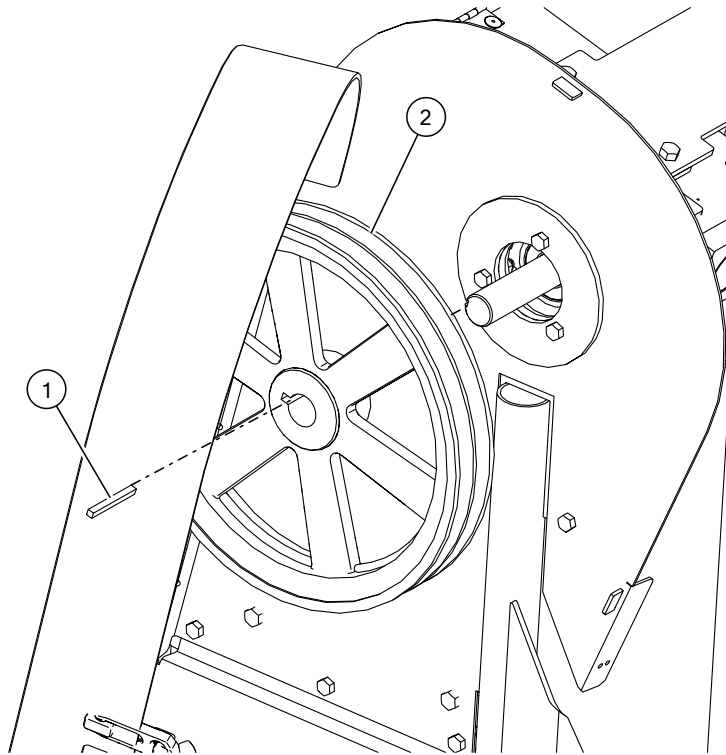

Assembly Notes:

- Ensure that the hub set screws are toward the inside (facing auger tube).
- The face of the gearbox shaft should be flush with the outside edge of the gearbox pulley.
- Use a straight edge to align the motor pulley with the gearbox pulley.

1	Square Key, 1/4" x 2-1/2"
2	Gearbox Pulley, Double

4.21.6 Install the Belt

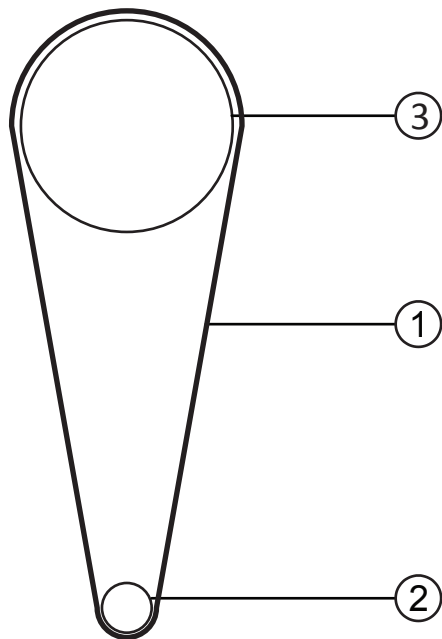

Assembly Note:

- The belt must run straight. Check the alignment of the pulleys and adjust if necessary.

1	Belt
2	Engine Pulley
3	Gearbox Pulley

4.22. Install the PTO-SD

4.22.1 Install the PTO Shield

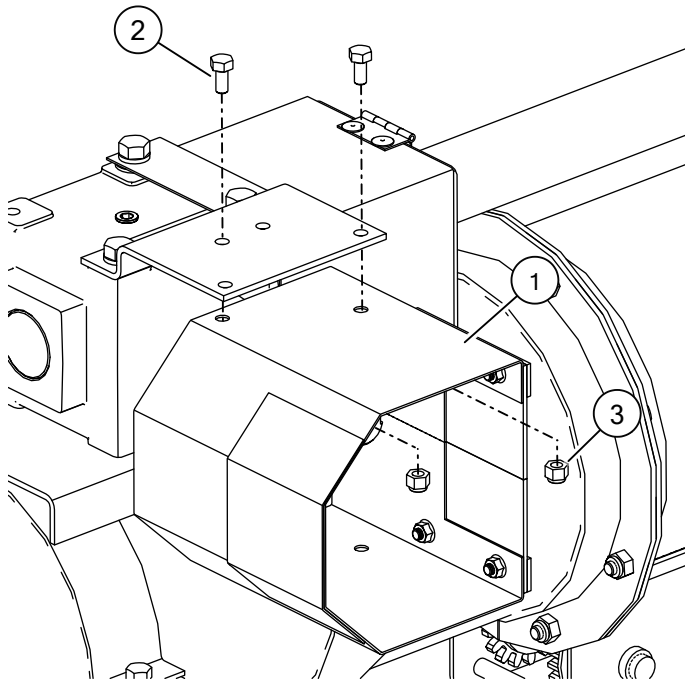

1	PTO Shield Assembly
2	Bolt, 3/8" x 3/4"
3	Locknut, 3/8"

4.22.2 Install the PTO

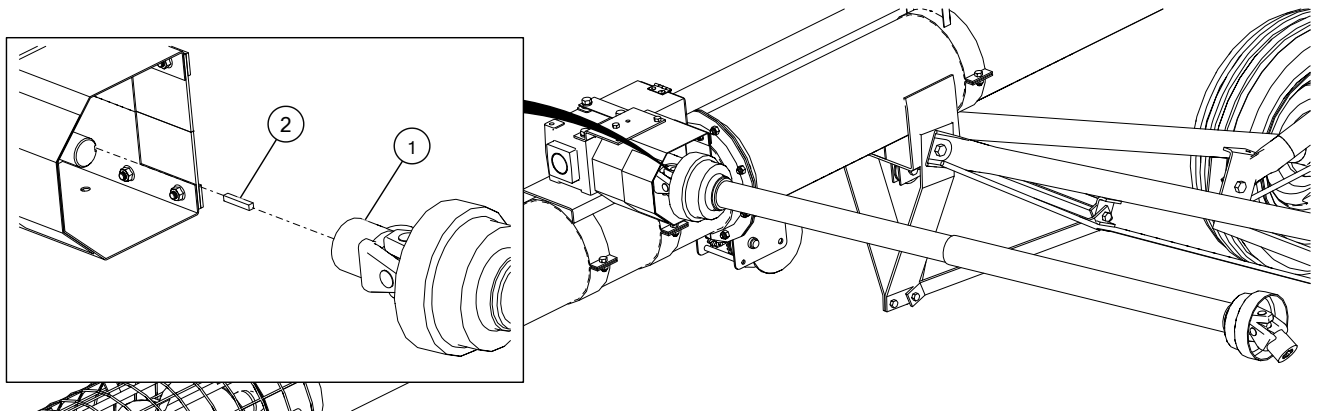

Assembly Notes:

- Clean paint and dirt from gearbox shaft and inside driveline yokes.
- The PTO driveline is non-separable type. Do not extend beyond 80".

1	PTO	2	Square Key, 1/4" x 1-1/2"
---	-----	---	---------------------------

4.22.3 Install the Saddle Bracket

Installing the Saddle Bracket

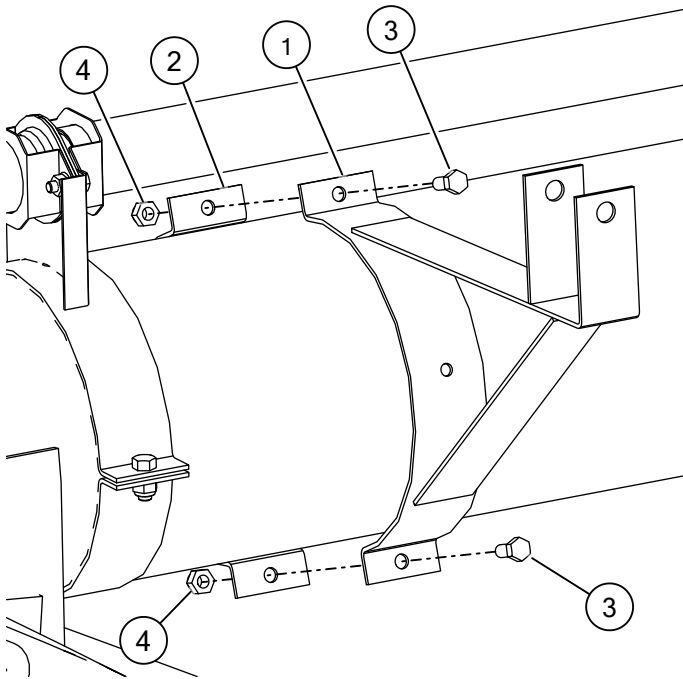

1	Saddle Bracket
2	Half Clamp
3	Bolt, 7/16" x 1"
4	Locknut, 7/16"

Securing the PTO

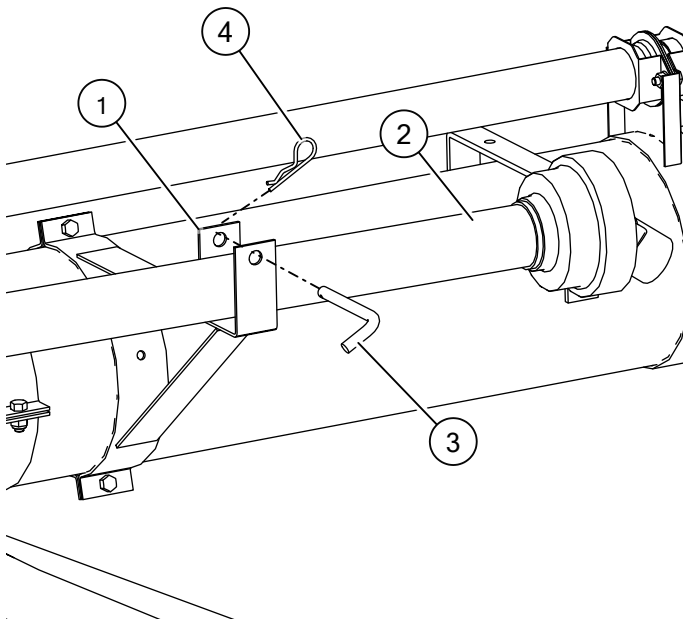

Assembly Note:	
<ul style="list-style-type: none"> Secure the PTO in the saddle bracket when not in use. 	
1	Saddle Bracket
2	PTO
3	Saddle Pin
4	Hitch Pin

4.23. Install the PTO-BD

4.23.1 Install Frame Support Tubes

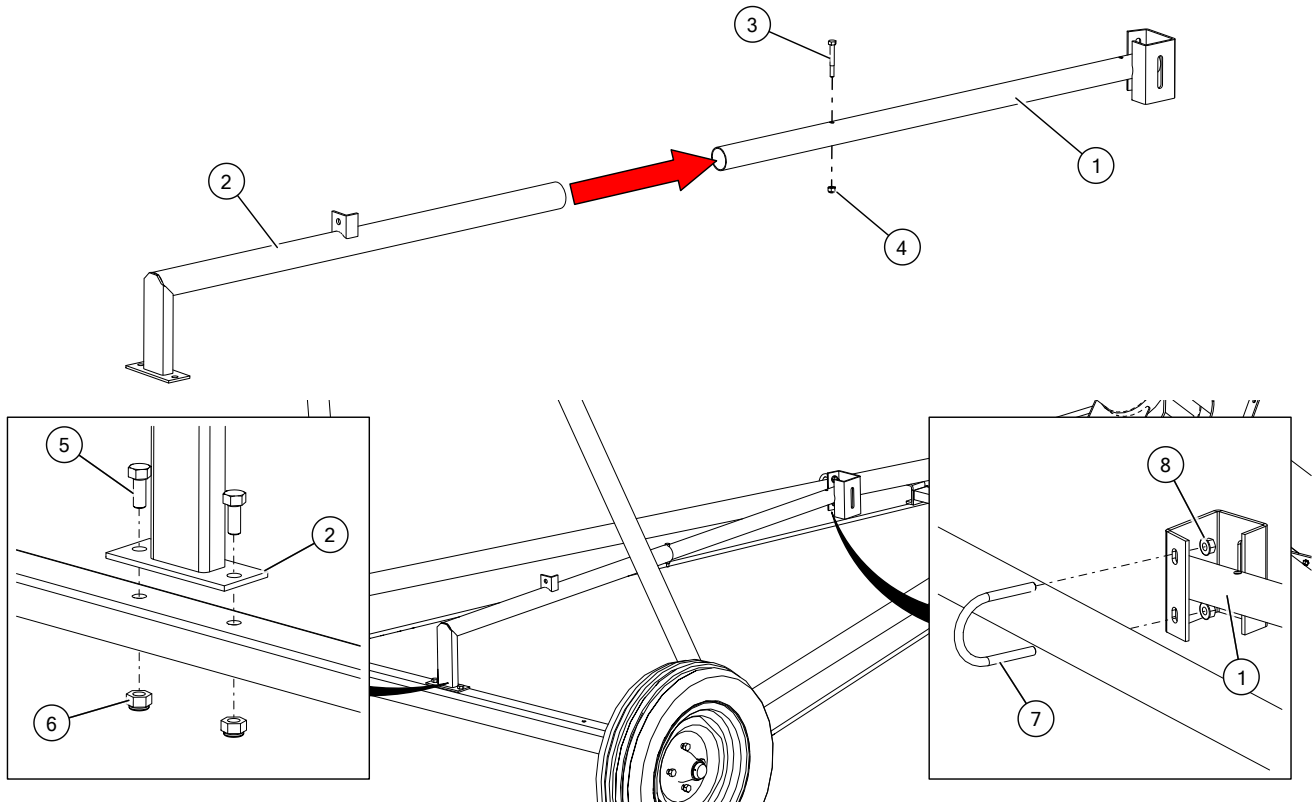

Assembly Notes:

- **46'/51' Models:** Bolt and nut are not required, as there is a welded plug in the inner support tube.
- Do not tighten the bolts fastening the inner support tube.

1	Inner Support Tube	6	Locknut, 7/16"
2	Outer Support Tube	7	U-Bolt, 3/8" x 2-1/2" (31' – 41' Models)
3	Bolt, 5/16" x 2-1/2" (31' – 41' Models)	7	U-Bolt, 3/8" x 3" (46'/51' Models)
4	Locknut, 5/16" (31' – 41' Models)	8	Whiznut, 3/8"
5	Bolt, 7/16" x 1"		

4.23.2 Install Jackshaft Assembly

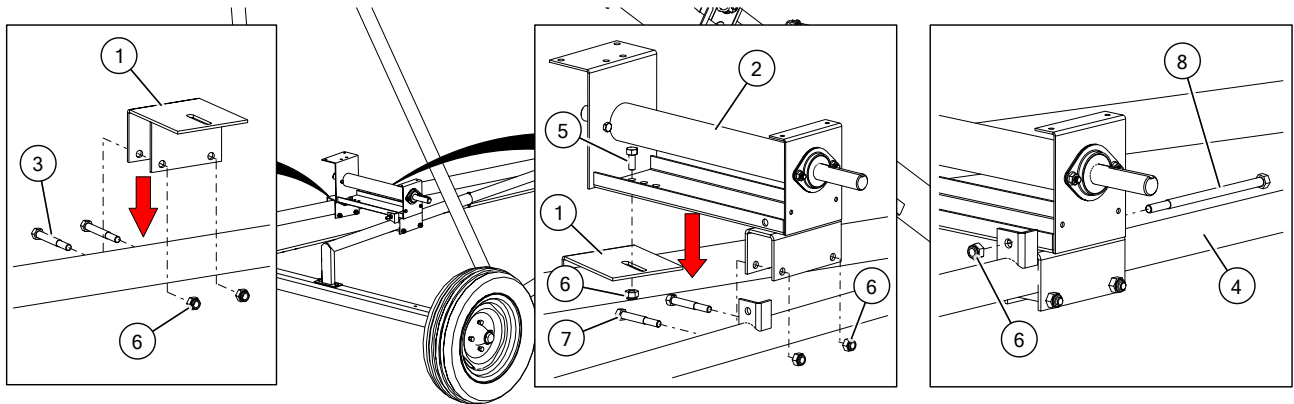

Assembly Notes:

- Do not tighten any bolts until belts are tensioned.
- Use 7/16" x 8" bolt to tension belt once installed.

1	Sliding Bracket	5	Bolt, 7/16" x 1"
2	Jackshaft Assembly	6	Locknut, 7/16"
3	Bolt, 7/16" x 3-1/2" (31' – 41' Models)	7	Bolt, 7/16" x 3"
	Bolt, 7/16" x 4" (46'/51' Models)	8	Bolt, 7/16" x 8"
4	Outer Support Tube		

4.23.3 Install the Pulleys

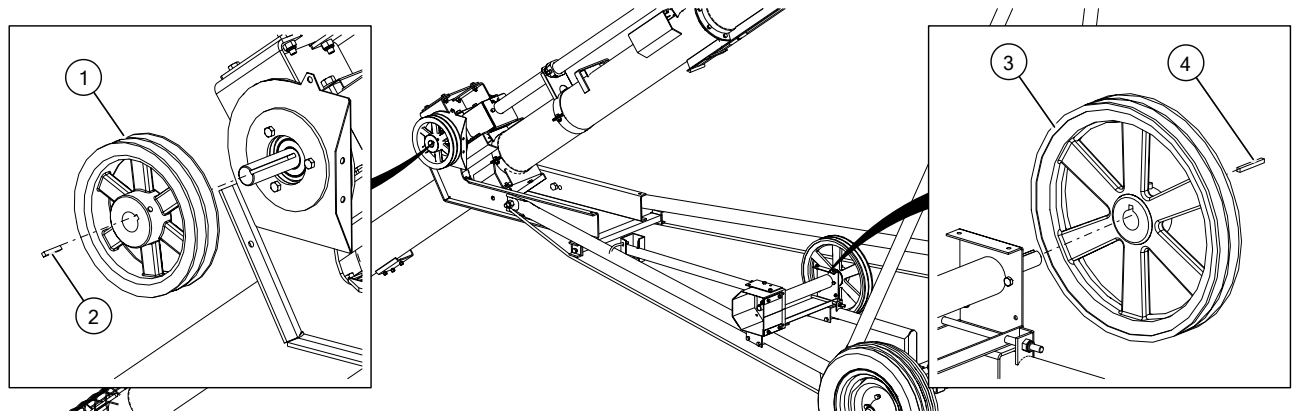

Assembly Notes:

- Before installing pulleys, clean all paint and dirt from the gearbox shaft, jackshaft, and inside pulley hubs.
- Make sure pulley hubs are facing inward (toward gearbox).

1	Gearbox Pulley, Double (7-3/4" OD)	3	Jackshaft Pulley, Double (15" OD)
2	Square Key, 1/4" x 1-1/2"	4	Square Key, 1/4" x 2-1/2"

4.23.4 Install the Belts

Belt Path

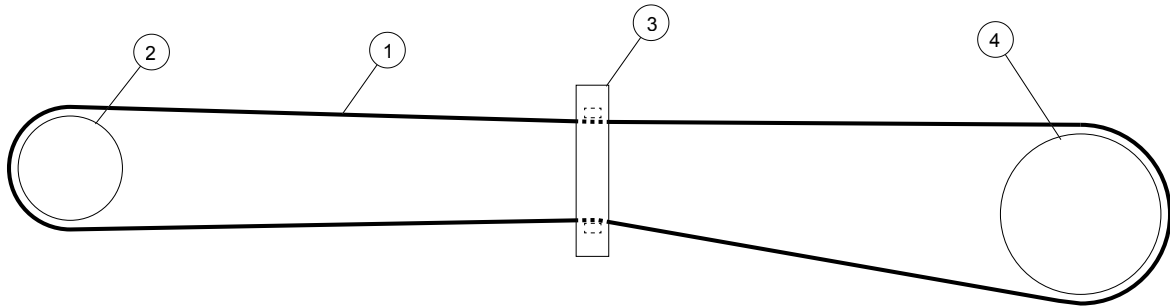

1	Belt	3	Belt Guide
2	Gearbox Pulley, Double (7-3/4" OD)	4	Jackshaft Pulley, Double (15" OD)

Installing the Belt Guide

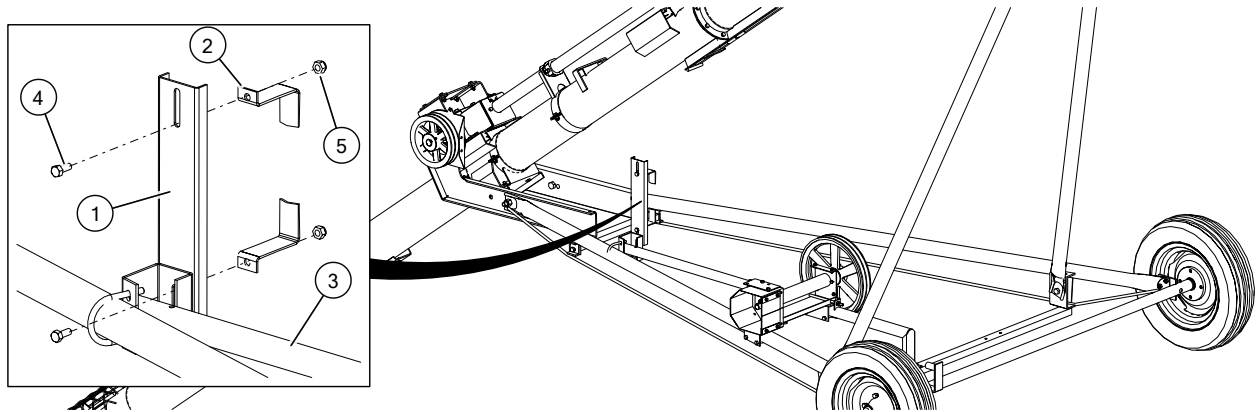

Assembly Notes:

- Belt must run straight. Check the alignment of the pulleys and adjust if necessary.
- Once belts are tensioned, tighten all previously installed hardware.

1	Belt Guide Support	4	Bolt, 7/16" x 1"
2	Belt Guide	5	Locknut, 7/16"
3	Inner Support Tube		

4.23.5 Install Pulley Guards

Overview

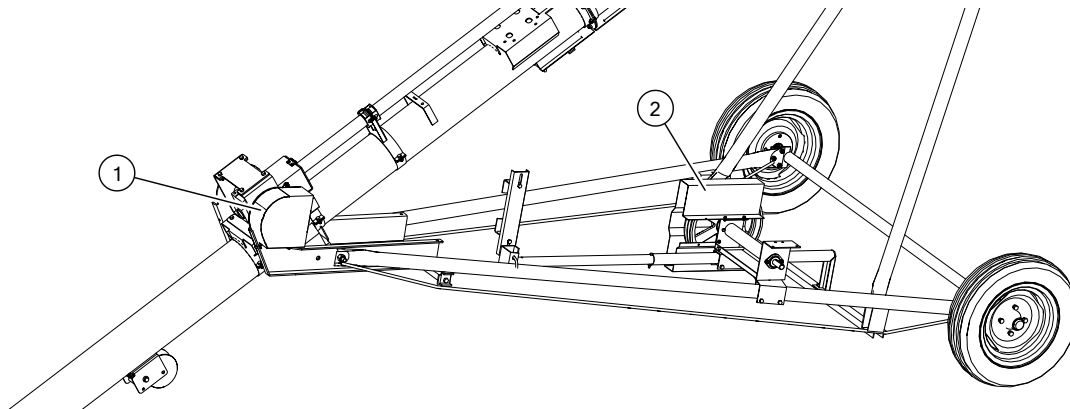

1	Gearbox Pulley Guard	2	Jackshaft Pulley Guard
---	----------------------	---	------------------------

Installing Gearbox Pulley Guard

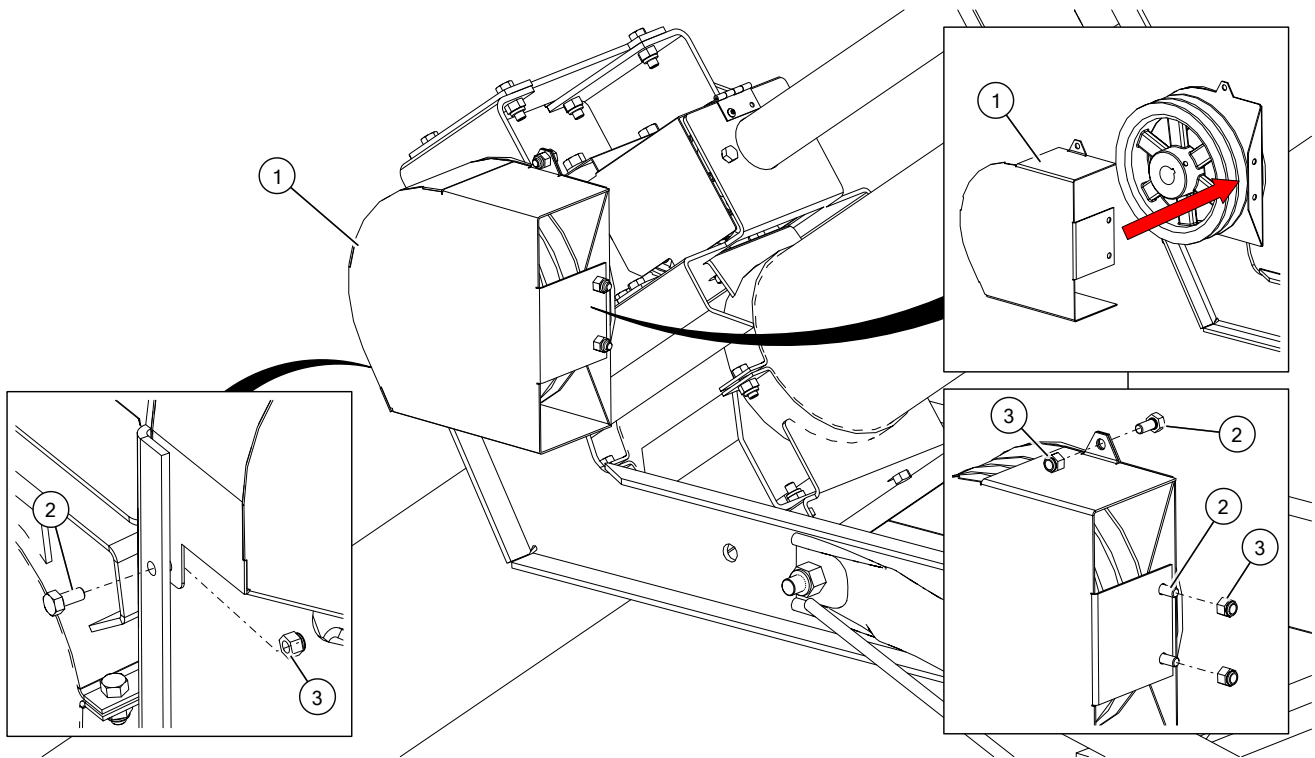

1	Gearbox Pulley Guard	3	Locknut, 3/8"
2	Bolt, 3/8" x 3/4"		

Installing Jackshaft Pulley Guard

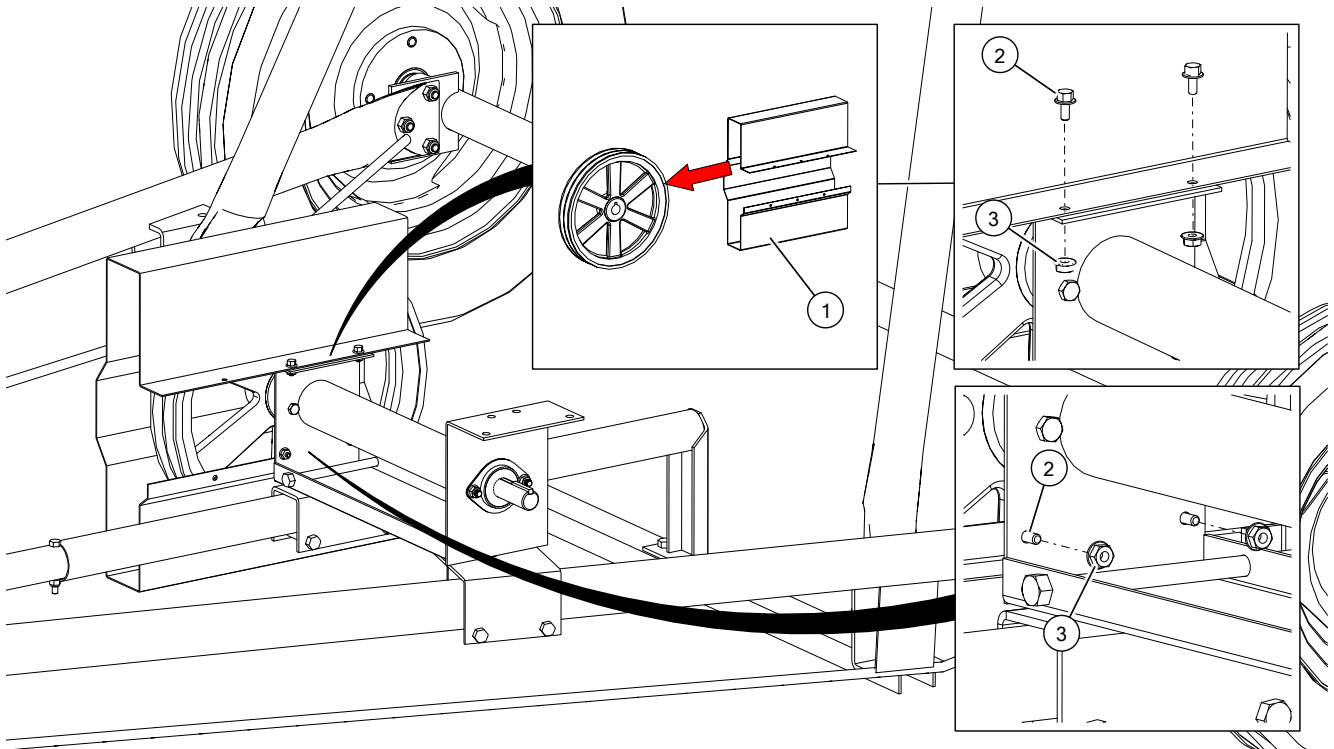

Assembly Note:

- The pulley guard is flexible.

1	Jackshaft Pulley Guard	3	Whiznut, 1/4"
2	Flange Bolt, 1/4" x 1/2"		

4.23.6 Install the PTO Shield

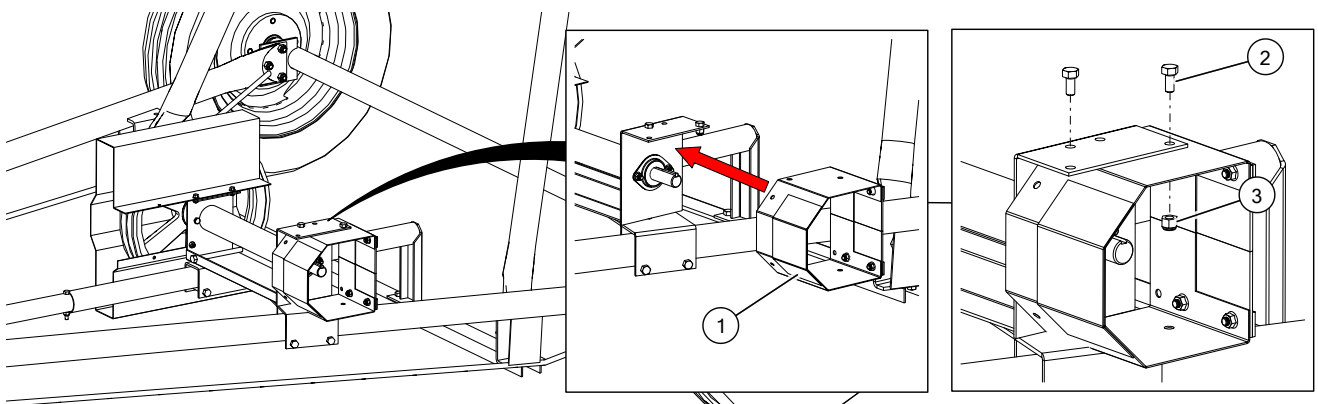

1	PTO Shield Assembly	3	Locknut, 3/8"
2	Bolt, 3/8" x 3/4"		

4.23.7 Install the PTO

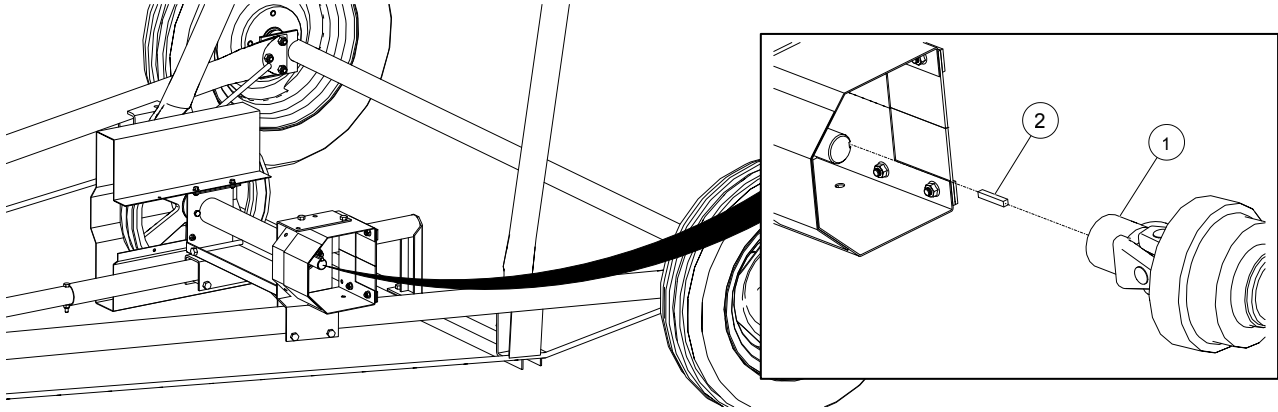

Assembly Notes:

- Clean paint and dirt from jackshaft and inside driveline yokes.
- The PTO driveline is non-separable type. Do not extend beyond 48".

1	PTO	2	Square Key, 1/4" x 1-1/2"
---	-----	---	---------------------------

4.23.8 Install PTO Transport Holder

Installing the PTO Transport Holder

31'/36'/41' Models

46'/51' Models

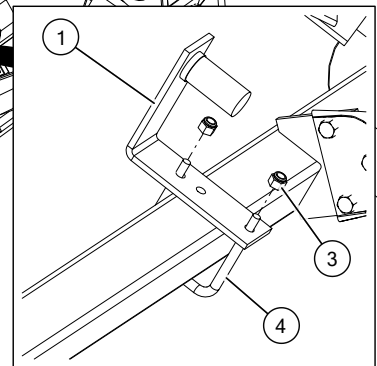
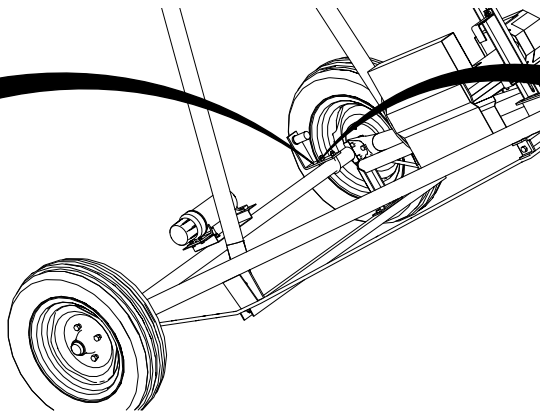
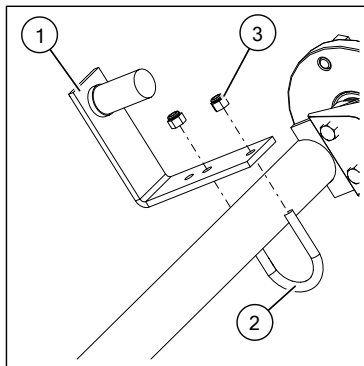

1	PTO Transport Holder	3	Locknut, 3/8"
2	U-Bolt, 3/8" x 2"	4	Square U-Bolt, 3/8" x 3-1/16" x 4"

4.24. Install the Hydraulic Drive

4.24.1 Install the Half Clamps

Installing the Half Clamps

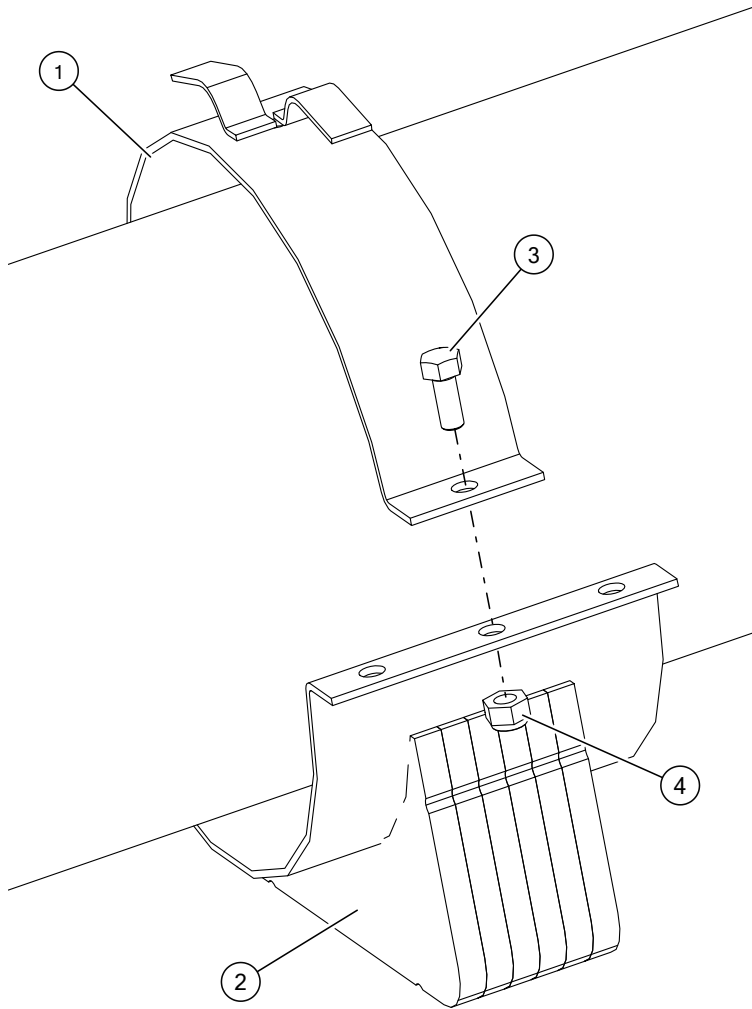

1	Hose Clip Half Clamp
2	Weighted Half Clamp
3	Bolt, 7/16" x 1"
4	Locknut, 7/16"

Half Clamp Locations

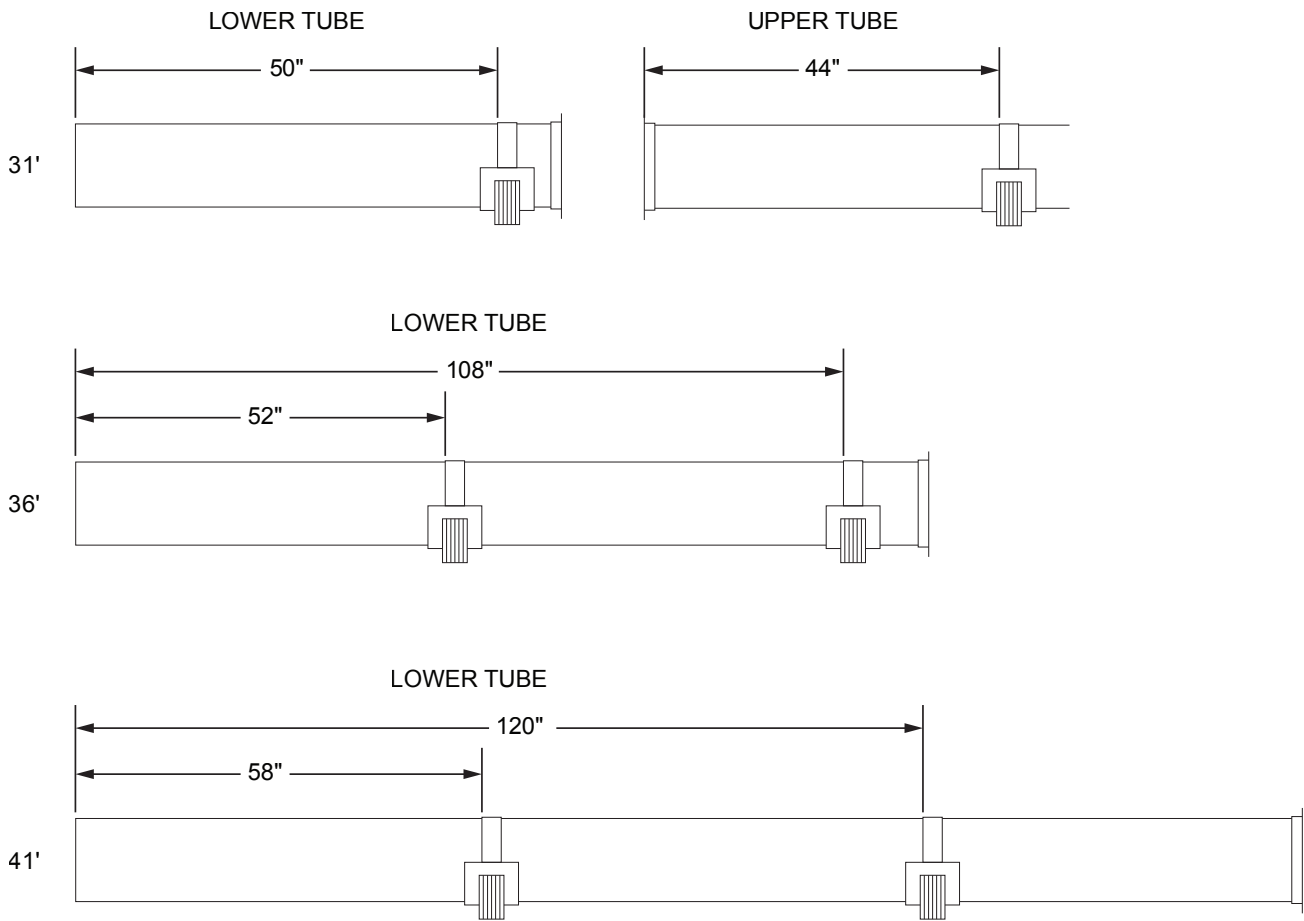

4.24.2 Install the Hydraulic Motor Mount Assembly

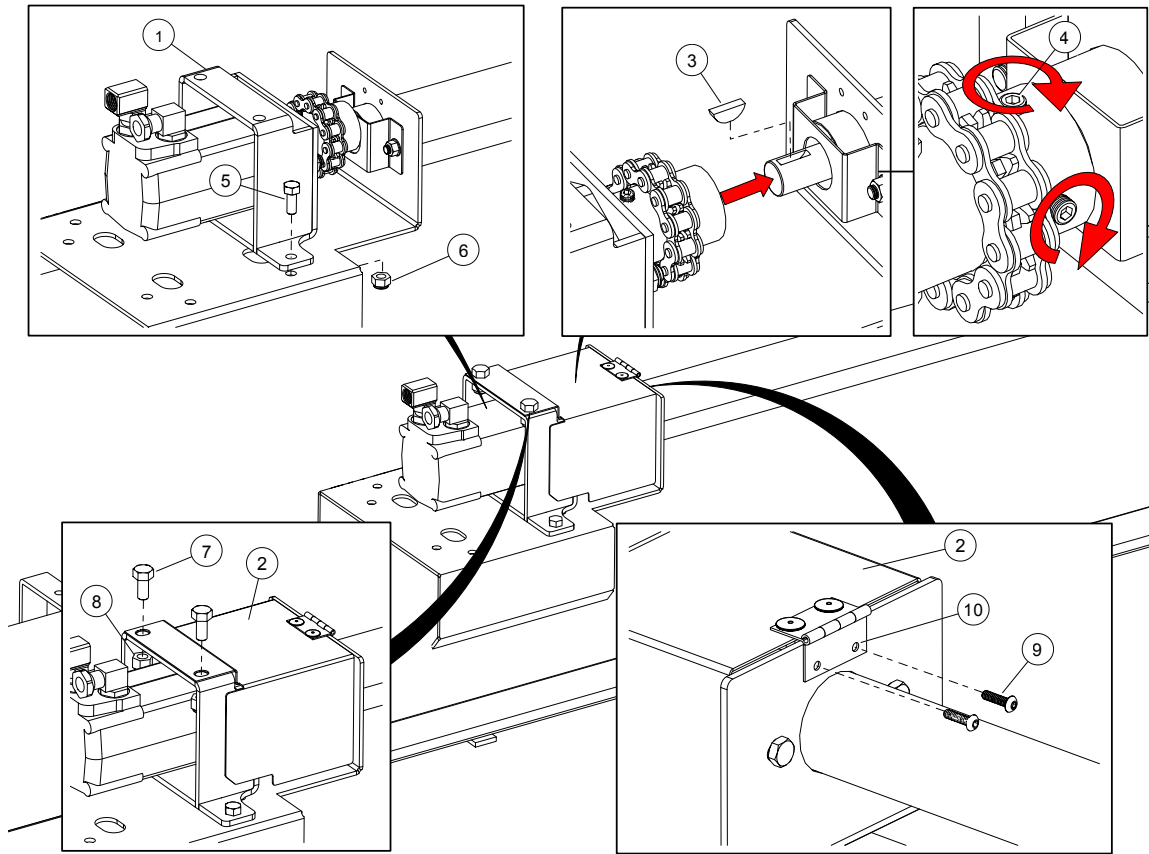

Assembly Notes:

- The ends of the hydraulic motor shaft and the driveshaft should be flush with the inside of the chain coupler sprockets.

If the driveshaft is too long or too short, do the following:

- If the driveshaft is too long, take up the extra length in the driveshaft connector(s).

Note

There may be more than one driveshaft connector in the drive system.

- If the driveshaft is too short, remove the headcover, chain, sprocket, and lock collar at the top of the upper tube to adjust the two driveshafts.

1	Hydraulic Motor Mount Assembly	6	Locknut, 7/16"
2	Chain Coupler Guard Assembly	7	Bolt, 1/2" x 1"
3	Woodruff Key, 1/4" x 1"	8	Locknut, 1/2"
4	Set Screw, 3/8" x 3/8"	9	Bolt, #10 x 3/4"
5	Bolt, 7/16" x 1"	10	Locknut, #10

4.24.3 Install the Hydraulic Hoses

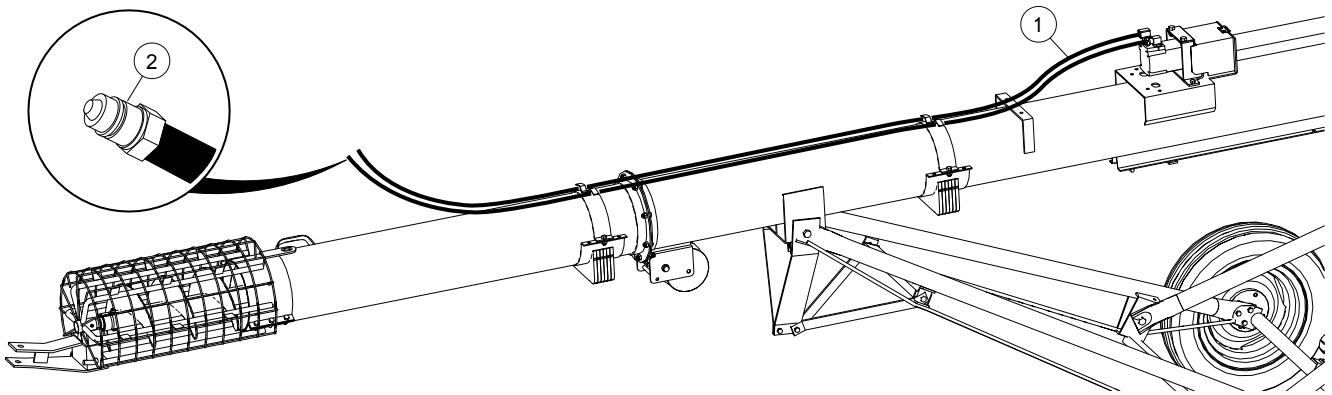

1	Hydraulic Hose, 1/2" x 165"	2	Pioneer Coupler
---	-----------------------------	---	-----------------

4.25. Install Manual Holder

31'/36'/41' Models

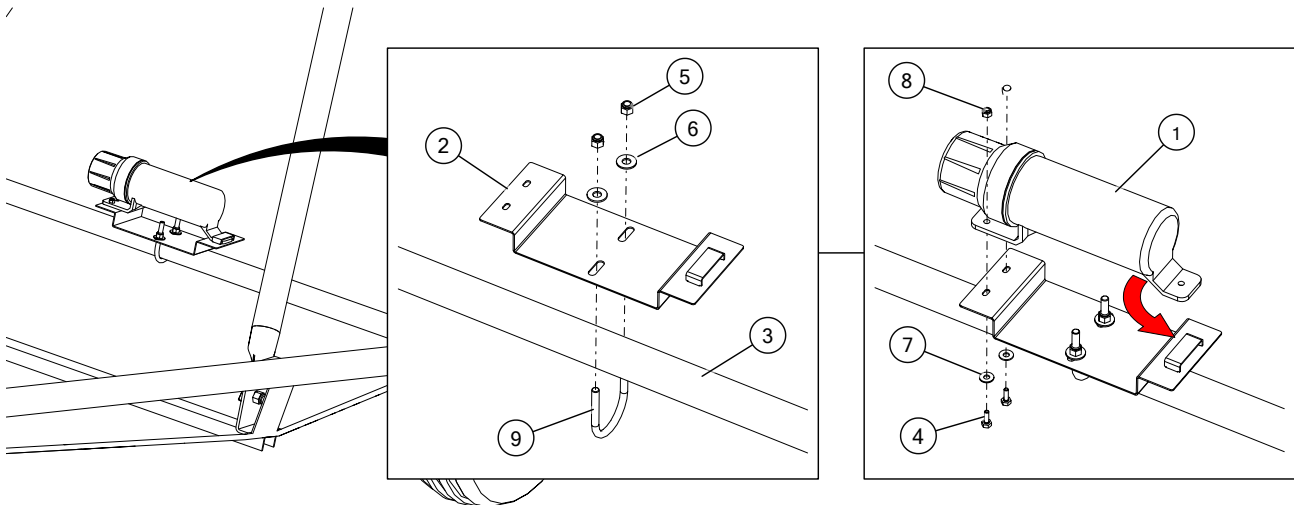

1	Manual Holder	6	Flat Washer 3/8"
2	Manual Holder Mount	7	Flat Washer, 1/4"
3	Axle	8	Locknut, 1/4"
4	Bolt, 1/4" x 3/4"	9	U-Bolt, 3/8" x 2-1/2"
5	Locknut, 3/8"		

46'/51'/56'/61'/71'/76'

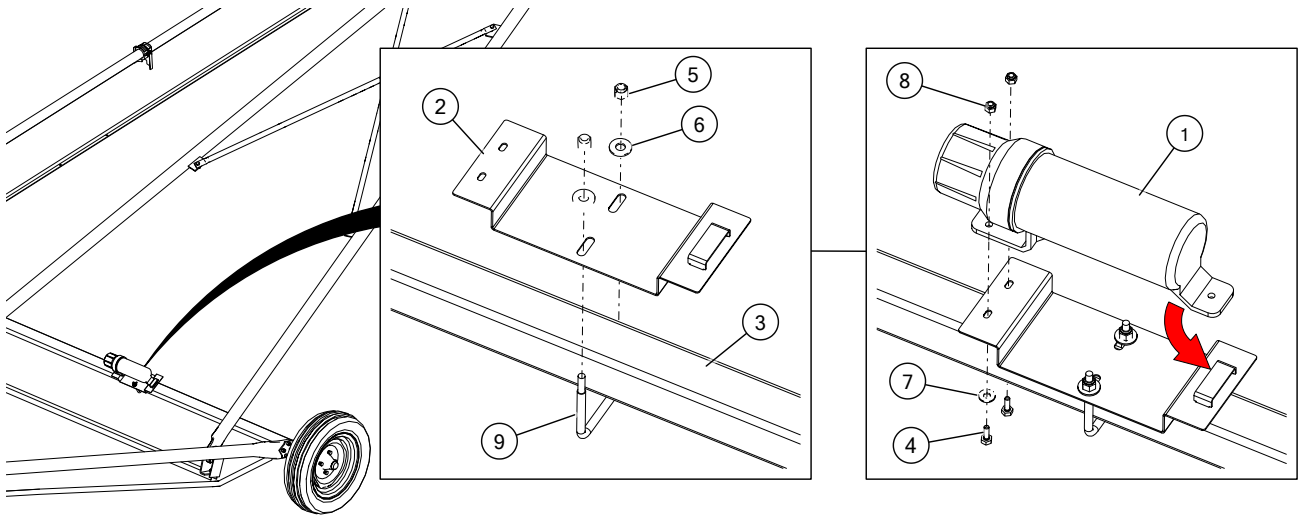

1	Manual Holder	6	Flat Washer 3/8"
2	Manual Holder Mount	7	Flat Washer, 1/4"
3	Axle	8	Locknut, 1/4"
4	Bolt, 1/4" x 3/4"	9	Square U-Bolt, 3/8" x 3-1/16" x 4"
5	Locknut, 3/8"		

5. Specifications

Specification	8-31	8-36	8-41
Tube Size	8" (203 mm)		
CAPACITIES			
Unloading Rate	Up to 3000 Bu/Hr (106 m ³ /Hr)		
TRANSPORT DIMENSIONS			
Length	32'7" (9.93 m)	36'5" (11.10 m)	42'5" (12.93 m)
Width	6'5" (1.96 m)	7'10" (2.39 m)	7'10" (2.39 m)
Height	9'3" (2.82 m)	10'10" (3.30 m)	11'0" (3.35 m)
DISCHARGE CLEARANCE DIMENSIONS			
Min	8'1" (2.46 m)	9'8" (2.95 m)	9'10" (3.00 m)
Min (BD)	9'9" (2.97 m)	10'10" (3.30 m)	11'7" (3.53 m)
Max (MD)	15'6" (4.72 m)	18'2" (5.54 m)	20'3" (6.17 m)
Max (BD)	20'6" (6.25 m)	24'6" (7.47 m)	28'5" (8.66 m)
Max (EMD/SD/HYD)	20'9" (6.32 m)	24'7" (7.49 m)	29'1" (8.86 m)
TIRES			
Type	15" Radial		
Inflation Pressure	20-24 PSI (137-165 kPa)		
WEIGHT			
Total Weight (Basic)	*680 lb (309 kg)	850 lb (386 kg)	*1020 lb (464 kg)
POWER RECOMMENDATIONS			
Gas Engine	16 HP	16-18 HP	18-20 HP
Electric Motor	5 HP	5-7.5 HP	5-7.5 HP
PTO Drive (SD & BD)	15 HP	15 HP	20 HP
Hydraulic	22GPM @ 2200 PSI	22GPM @ 2200 PSI	22GPM @ 2200 PSI
PART SPECIFICATIONS			
Gas Tank Capacity (MD)	47.6 US quarts (45 L)		
Lubricating Grease	SAE multi-purpose high-temperature grease with extreme pressure (EP) performance. (SAE multi-purpose lithium-based grease is also acceptable)		
Gearbox Oil	SAE approved 90W or equivalent gear oil		
Gearbox Oil Capacity (MD/EMD/SD)	0.9 US quarts (0.85 L)		
Upper Drive Housing Grease Quantity	1100 g (40 oz)		
Belt Size (MD)	B100		
Belt Size (BD)	B160	B210 Double Banded	
Belt Size (EMD)	B62		
Maximum Operating Angle (SD & BD)	15°		
Hydraulic Hoses	Minimum 2500 psi (17200 kPa) working pressure		

*Weights are estimated

Specification	8-46	8-51	8-56	8-61	8-71	8-76
Tube Size	8" (203 mm)					
CAPACITIES						
Unloading Rate	Up to 3000 Bu/Hr (106 m ³ /Hr)					
TRANSPORT DIMENSIONS						
Length	46'8" (14.2 m)	52'2" (15.9 m)	56'10" (17.3 m)	62'2" (18.9 m)	72'0" (21.9 m)	76'10" (23.4 m)
Width	9'6" (2.9 m)	9'6" (2.9 m)	10'0" (3.0 m)	10'0" (3.0 m)	10'6" (3.2 m)	10'6" (3.2 m)
Height	12'0" (3.7 m)	11'9" (3.6 m)	12'2" (3.7 m)	12'2" (3.7 m)	13'6" (4.1 m)	11'5" (3.2 m)
DISCHARGE CLEARANCE DIMENSIONS						
Min	10'5" (3.18 m)	10'5" (3.18 m)	11'5" (3.48 m)	11'0" (3.35 m)	12'4" (3.76 m)	10'10" (3.30 m)
Min (BD)	11'5" (3.48 m)	11'11" (3.63 m)	N/A	N/A	N/A	N/A
Max (MD)	N/A	N/A	N/A	N/A	N/A	N/A
Max (BD)	31'5" (9.75 m)	35'6" (10.82 m)	N/A	N/A	N/A	N/A
Max (EMD/SD/HYD)	31'3" (9.52 m)	35'0" (10.67 m)	37'5" (11.40 m)	40'1" (12.22 m)	46'5" (14.15 m)	45'5" (13.84 m)
TIRES						
Type	15" Radial					
Inflation Pressure	20-24 PSI (137-165 kPa)					
WEIGHT						
Total Weight (Basic)	1180 lb (536 kg)	*1350 lb (614 kg)	1520 lb (691 kg)	*1690 lb (768 kg)	*2030 lb (923 kg)	*2160 lb (982 kg)
POWER RECOMMENDATIONS						
Gas Engine	N/A	N/A	N/A	N/A	N/A	N/A
Electric Motor	7.5 HP	10-15 HP	15 HP	15-20 HP	20 HP	20-25 HP
PTO Drive (SD & BD)	25 HP	25 HP	30 HP	35 HP	45 HP	50 HP
Hydraulic	N/A	N/A	N/A	N/A	N/A	N/A
PART SPECIFICATIONS						
Gas Tank Capacity (MD)	N/A					
Lubricating Grease	SAE multi-purpose high-temperature grease with extreme pressure (EP) performance. (SAE multi-purpose lithium-based grease is also acceptable)					
Gearbox Oil	SAE approved 90W or equivalent gear oil					
Gearbox Oil Capacity (MD/EMD/SD)	0.9 US quarts (0.85 L)					
Upper Drive Housing Grease Quantity	1100 g (40 oz)					
Belt Size (MD)	N/A					
Belt Size (BD)	B270 Double Banded	N/A				

Specification	8-46	8-51	8-56	8-61	8-71	8-76
Belt Size (EMD)	B62					
Maximum Operating Angle (SD & BD)	15°					
Hydraulic Hoses	Minimum 2500 psi (17200 kPa) working pressure					

*Weights are estimated

Specification	10-31	10-36	10-41	10-51	10-61	10-71
Tube Size	10" (254 mm)					
CAPACITIES						
Unloading Rate	Up to 4800 Bu/Hr (169 m ³ /Hr)					
TRANSPORT DIMENSIONS						
Length	32'7" (9.93 m)	36'5" (11.10 m)	42'5" (12.93 m)	52'2" (15.9 m)	62'2" (18.9 m)	72'0" (21.9 m)
Width	6'5" (1.96 m)	7'10" (2.39 m)	7'10" (2.39 m)	9'6" (2.9 m)	10'0" (3.0 m)	10'6" (3.2 m)
Height	9'3" (2.82 m)	10'10" (3.30 m)	11'0" (3.35 m)	11'9" (3.6 m)	12'2" (3.7 m)	13'6" (4.1 m)
DISCHARGE CLEARANCE DIMENSIONS						
Min	8'1" (2.46 m)	9'8" (2.95 m)	9'10" (3.00 m)	10'5" (3.18 m)	11'0" (3.35 m)	12'4" (3.76 m)
Min (BD)	9'9" (2.97 m)	10'10" (3.30 m)	11'7" (3.53 m)	11'11" (3.63 m)	N/A	N/A
Max (MD)	15'6" (4.72 m)	18'2" (5.54 m)	20'3" (6.17 m)	N/A	N/A	N/A
Max (BD)	20'6" (6.25 m)	24'6" (7.47 m)	28'5" (8.66 m)	35'6" (10.82 m)	N/A	N/A
Max (EMD/SD/HYD)	20'9" (6.32 m)	24'7" (7.49 m)	29'1" (8.86 m)	35'0" (10.67 m)	40'1" (12.22 m)	46'5" (14.15 m)
TIRES						
Type	15" Radial					
Inflation Pressure	20-24 PSI (137-165 kPa)					
WEIGHT						
Total Weight (Basic)	990 lb (449 kg)	1110 lb (504 kg)	1220 lb (553 kg)	1660 lb (755 kg)	1970 lb (895 kg)	2160 lb (982 kg)
POWER RECOMMENDATIONS						
Gas Engine	18-20 HP	22-25 HP	22-25 HP	N/A	N/A	N/A
Electric Motor	7.5-10 HP	10-15 HP	10-15 HP	15-20 HP	20 HP	20-25 HP
PTO Drive (SD & BD)	30 HP	35 HP	40 HP	45 HP	55 HP	60 HP
Hydraulic	22GPM @ 2200 PSI	22GPM @ 2200 PSI	22GPM @ 2200 PSI	N/A	N/A	N/A
PART SPECIFICATIONS						
Gas Tank Capacity (MD)	47.6 US quarts (45 L)			N/A		

Specification	10-31	10-36	10-41	10-51	10-61	10-71
Lubricating Grease	SAE multi-purpose high-temperature grease with extreme pressure (EP) performance. (SAE multi-purpose lithium-based grease is also acceptable)					
Gearbox Oil	SAE approved 90W or equivalent gear oil					
Gearbox Oil Capacity (MD/EMD/SD)	0.9 US quarts (0.85 L)					
Upper Drive Housing Grease Quantity	1100 g (40 oz)					
Belt Size (MD)	B100			N/A		
Belt Size (BD)	B160	B210 Double Banded		B270 Double Banded	N/A	
Belt Size (EMD)	B62					
Maximum PTO Operating Angle (SD & BD)	15°					
Hydraulic Hoses	Minimum 2500 psi (17200 kPa) working pressure					

6. Appendix

6.1. Bolt Torque

Table 2 gives the correct torque values for various hardware. Tighten all bolts to the torque specified, unless otherwise noted. Check tightness periodically, using Table 2 as a guide. Replace the hardware with the same strength bolt, contact Westfield if you are unsure.

Table 2. Recommended Bolt Torque¹

Size	Dry or Lubricated	Threads per inch (Course/Fine)	Area of Bolt (sq in.)		Recommended Torque (ft-lb)							
					Grade 2		Grade 5		Grade 8		8.8 S/S	
					Coarse	Fine	Coarse	Fine	Coarse	Fine	Coarse	Fine
1/4"	Dry	20/28	0.0318	0.0364	5.5	6.3	8	10	12	14	6.3	7.8
	Lubricated				6.3	4.7	6.3	7.2	9	10	-	-
5/16"	Dry	18/24	0.0524	0.058	11	12	17	19	24	27	11	11.8
	Lubricated				8	9	13	14	18	20	-	-
3/8"	Dry	16/24	0.0775	0.0878	20	23	30	35	45	50	20	22
	Lubricated				15	17	23	25	35	35	-	-
7/16"	Dry	14/20	0.1063	0.1187	32	36	50	55	70	80	31	33
	Lubricated				24	27	35	40	50	80	-	-
1/2"	Dry	13/20	0.1419	0.1599	50	55	75	85	110	120	43	45
	Lubricated				35	40	55	65	80	90	-	-
9/16"	Dry	12/18	0.182	0.203	70	80	110	120	150	170	57	63
	Lubricated				55	60	80	90	110	130	-	-
5/8"	Dry	11/18	0.226	0.256	100	110	150	170	210	240	93	104
	Lubricated				75	85	110	130	160	180	-	-
3/4"	Dry	10/16	0.334	0.373	175	200	260	300	380	420	128	124
	Lubricated				130	140	200	220	280	310	-	-
7/8"	Dry	9/14	0.462	0.508	170	180	430	470	600	670	194	193
	Lubricated				125	140	320	350	180	180	-	-
1"	Dry	8/14	0.606	0.679	250	280	640	720	910	1020	287	289
	Lubricated				190	210	480	540	680	760	-	-
1-1/8"	Dry	7/12	0.763	0.856	350	400	790	890	1290	1440	288	290
	Lubricated				270	300	590	670	970	1080	-	-
1-1/4"	Dry	7/12	0.989	1.073	500	550	1120	1240	1820	2010	289	291
	Lubricated				380	420	840	930	1360	1510	-	-
1-1/2"	Dry	6/12	1.405	1.581	870	960	1950	2200	3160	3560	-	-
	Lubricated				650	730	1460	1640	2370	2670	-	-

1. Torque value for bolts and cap screws are identified by their head markings. Established at 75% of yield strength of bolt given the cross-sectional area.

Note

Torque figures in table are valid for non-greased or non-oiled threads and head unless otherwise specified. Therefore, do not grease or oil bolts or cap screws unless otherwise specified in this manual. When using locking elements, increase torque values by 5%.



P.O. Box 39
Rosenort, Manitoba, R0G 1W0 Canada
Phone: (866) 467-7207 (Canada & USA) or (204) 746-2396
Fax: (866) 768-4852

Website: www.grainaugers.com
Email: sales@grainaugers.com
©Ag Growth International Inc. 2020
Printed in Canada

If you have any comments or questions on this manual, or find an error, email us at comments@aggrowth.com.
Please include the part number listed on the cover page in your message.