

# A HUTCHINSON COMMERCIAL UNLOAD PRODUCT

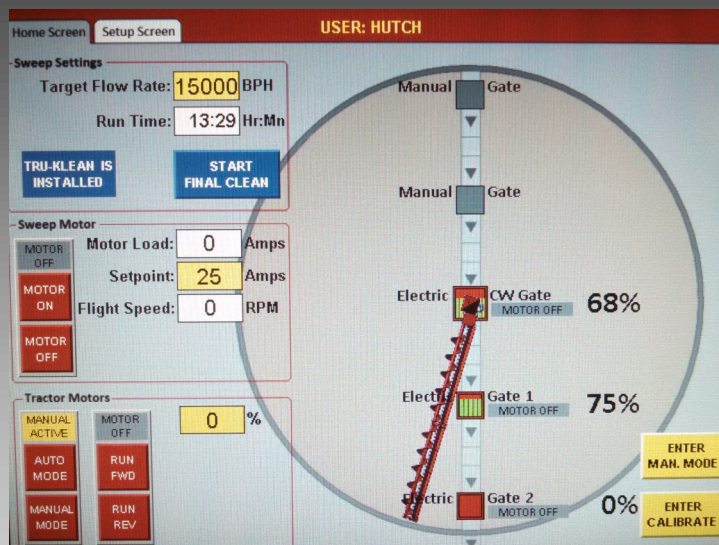

HOME SCREEN

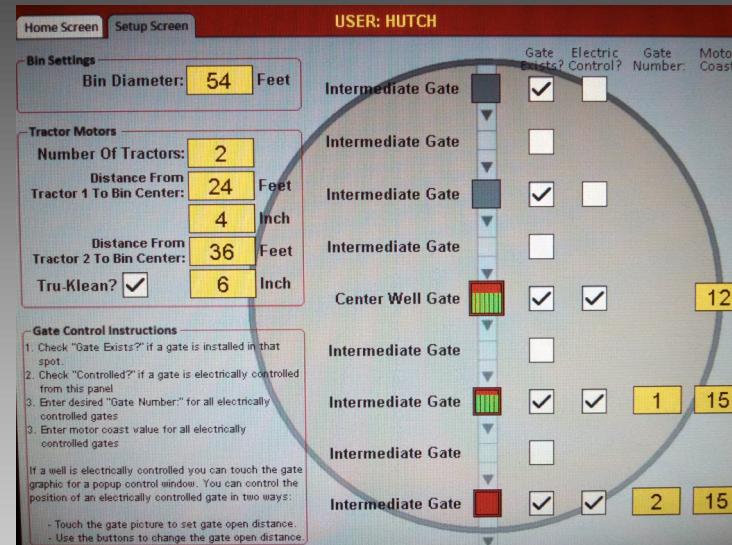

SETUP SCREEN

## TOUCH SCREEN CONTROL PANEL

- ADJUSTABLE CAPACITY SETTINGS FROM 7,500 BPH UP TO 15,000 BPH
- ADJUSTABLE ELECTRONIC SWEEP CONTROL
- PANEL DISPLAYS THE ACTUAL LOCATION OF THE SWEEP DURING OPERATION
- SEND TO HOME FEATURE

# HUTCHINSON

## NEXGEN 3000 SERIES COMMERCIAL SWEEP

“A KEY COMPONENT TO ZERO BIN ENTRY OPERATION”



## MODEL 3150

- 15,000 BPH CAPACITY
- 50,000 BPH FREE-FLOWING CAPACITY THROUGH CENTERWELL
- TRU-KLEAN CHAIN & PADDLE OPTION PROVIDES NEAR BROOM SWEPT FINISH
- AVAILABLE FOR BINS 48' TO 150' DIAMETER
- TOUCHSCREEN CONTROL PANEL

WATCH THE 3150 IN OPERATION ON OUR NEW YOUTUBE CHANNEL!

COMPLIMENTED BY COMPARISON



**HUTCHINSON/MAYRATH**  
A Division of GLOBAL Industries, Inc.



WWW.FACEBOOK.COM/HUTCHINSONMAYRATH



514 W. CRAWFORD ST | CLAY CENTER, KS 67432 | 800.523.6993 | WWW.HUTCHINSON-MAYRATH.COM



**TRACTORS**

- REDUCTION DRIVE GEARBOX
- 4 SOLID RUBBER DRIVE WHEELS
- FLOATING FRAME DESIGN

**CENTER WELL**

- 48" SQUARE BY 18" DEEP
- ABOVE FLOOR SLIP RING
- UP TO 50,000 BPH

FREE-FLOWING CAPACITY

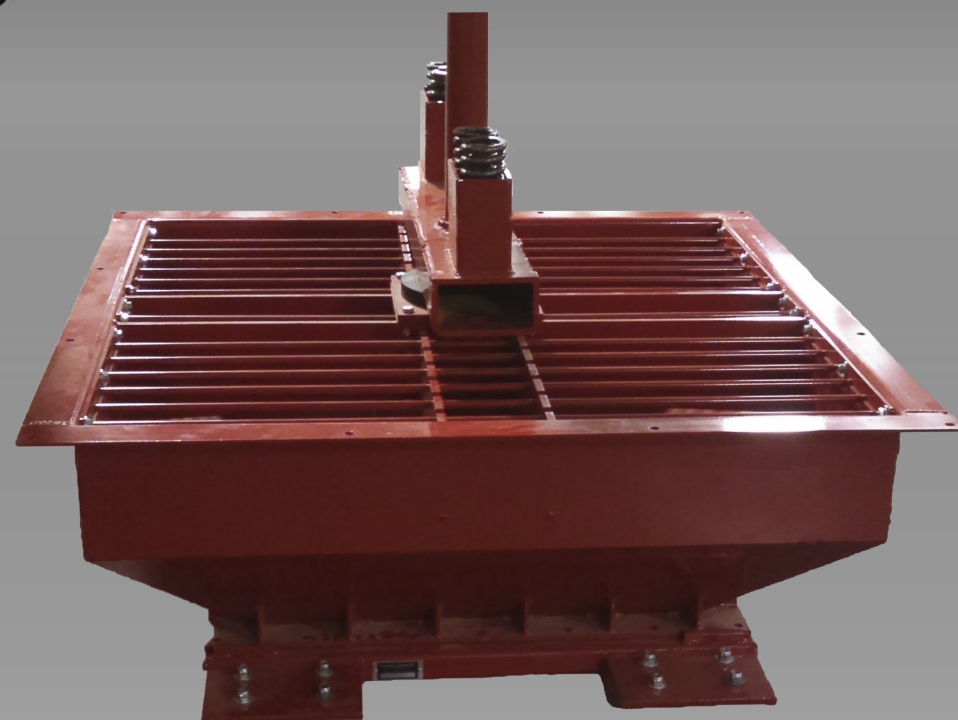

**ADDITIONAL FEATURES**

- DIRECT DRIVE C-FACE REDUCER
- NO BELTS OR PULLEYS
- INTEGRATED SUPPORT SPRINGS REDUCE FLOOR PRESSURE
- 18" O.D. 3/8" FLIGHT ON 4" O.D. TUBE

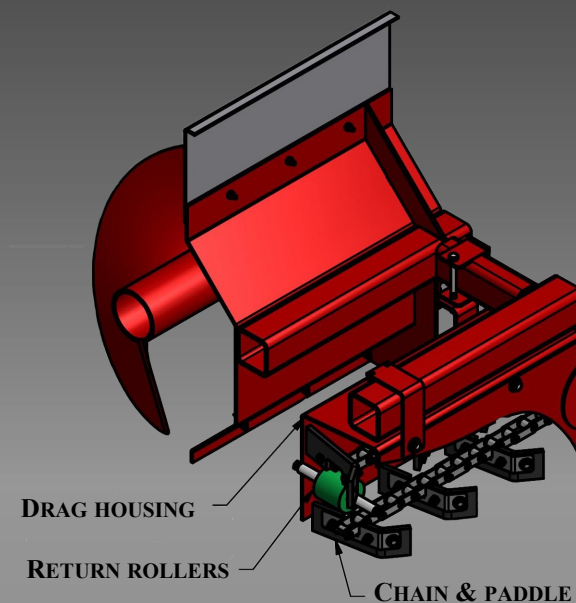

DRAG HOUSING  
RETURN ROLLERS  
CHAIN & PADDLE

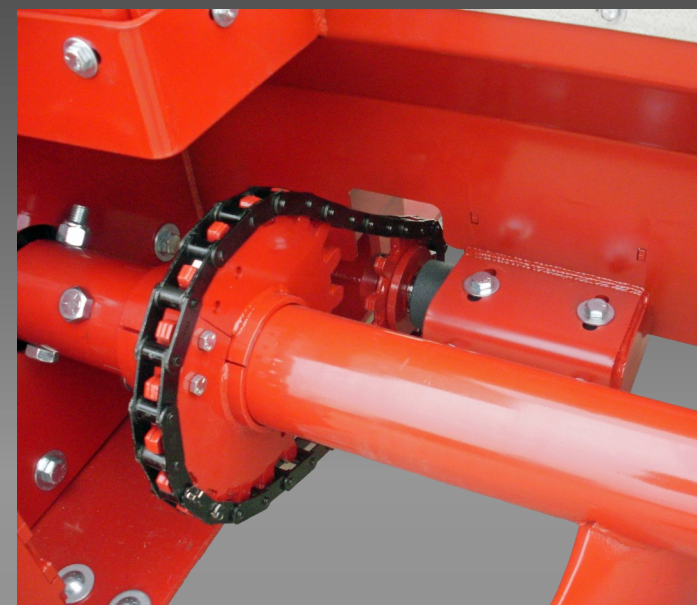

**OPTIONAL TRU-KLEAN CHAIN & PADDLE SWEEP**

- CHAIN & PADDLES FLOAT ACROSS THE FLOOR BEHIND THE SWEEP
- UTILIZES RETURN ROLLERS FOR REDUCED FRICTION
- DRAG IS POWERED DIRECTLY FROM THE SWEEP AUGER
- PULLS ADDITIONAL GRAIN INTO THE CENTER WELL FOR A NEAR BROOM SWEPT FINISH

